

SITE DEVELOPMENT PLANS FOR DALTON LIBRARY CAPPES STREET

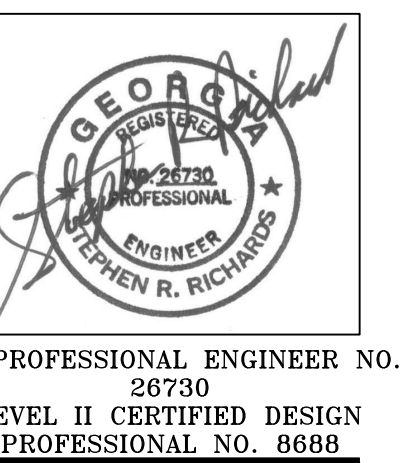

1. THESE PLANS HAVE BEEN SIGNED AND SEALED FOR REVIEW ONLY. THEY CANNOT BE USED FOR CONSTRUCTION UNTIL THEY HAVE BEEN APPROVED, STAMPED AND SIGNED BY THE APPROPRIATE AUTHORITIES AND ALL NECESSARY PERMITS HAVE BEEN OBTAINED BY THE CLIENT.
2. THE CLIENT IS ULTIMATELY RESPONSIBLE FOR OBTAINING THE APPROPRIATE PERMITS FOR CONSTRUCTION FROM ALL FEDERAL, STATE AND LOCAL PERMITTING AUTHORITIES. RICHARDS & ASSOCIATES ENGINEERING, INC. IS NOT LIABLE FOR THE FAILURE OF THE CLIENT TO OBTAIN THE NECESSARY PERMITS.
3. THIS DRAWING SHEET IS PART OF A COMPLETE SET OF DESIGN DRAWINGS. IT SHOULD NOT BE SEPARATED FROM THE SET. INFORMATION PERTINENT TO THIS SHEET MAY BE FOUND ON OTHER SHEETS IN THE SET.
4. A COPY OF THE CURRENT SET OF APPROVED DRAWINGS MUST BE KEPT ON THE CONSTRUCTION SITE AT ALL TIMES.
5. THE CLIENT IS RESPONSIBLE FOR ENSURING THAT THE CONTRACTOR HAS A COPY OF THE CURRENT SET OF APPROVED DRAWINGS ONSITE AT ALL TIMES.
6. IF ANY CONFLICTS, DISCREPANCIES, OR OTHER UNSATISFACTORY CONDITIONS ARE DISCOVERED, EITHER ON THE CONSTRUCTION DOCUMENTS OR THE FIELD CONDITIONS, THE CONTRACTOR MUST NOTIFY THE ENGINEER IMMEDIATELY, AND SHALL NOT COMMENCE OPERATION UNTIL THE CONFLICTS, DISCREPANCIES, OR OTHER UNSATISFACTORY CONDITIONS ARE RESOLVED. RICHARDS & ASSOCIATES ENGINEERING, INC. WILL NOT BE RESPONSIBLE FOR CONFLICTS IF WE ARE NOT NOTIFIED PRIOR TO INSTALLATION.
7. THESE DRAWINGS HAVE BEEN STAMPED AND SIGNED ENGINEERING DESIGN CONTENT ONLY. PROPERTY LINE INFORMATION SHOWN ON THESE DRAWINGS HAS BEEN PROVIDED BY THE CLIENT OR A REGISTERED LAND SURVEYOR AND ARE SHOWN FOR REFERENCE ONLY. THE CLIENT MUST ENGAGE THE SERVICES OF A REGISTERED LAND SURVEYOR TO RESEARCH, PLAT AND LOCATE ALL PROPERTY CORNERS PRIOR TO THE PURCHASE OF THE PROPERTY AND COMMENCEMENT OF CONSTRUCTION. RICHARDS & ASSOCIATES ENGINEERING, INC. IS NOT RESPONSIBLE FOR VERIFYING THE LOCATION OF OR EXISTENCE OF THE LIMITS OR BOUNDARY OF THE CLIENT'S PROPERTY. AT THE CLIENT'S REQUEST, RICHARDS & ASSOCIATES ENGINEERING, INC. USES THE INFORMATION PROVIDED BY THE CLIENT, EITHER DIRECTLY OR THROUGH THE CLIENT'S SURVEYOR, TO PRODUCE CONSTRUCTION DRAWINGS FOR THE CLIENT. THESE DRAWINGS MAY HAVE BEEN PREPARED FOR A SITE NOT CURRENTLY OWNED BY THE CLIENT. THE CLIENT IS RESPONSIBLE FOR ENSURING THAT HE HAS THE RIGHT TO OCCUPY THE PROPERTY FOR THE PURPOSE OF CONSTRUCTION. RICHARDS & ASSOCIATES ENGINEERING, INC. MAKES NO CLAIMS AS TO THE OWNERSHIP OF THE SUBJECT PROPERTY OR ADJACENT PROPERTIES.

LOCATED IN LAND LOT 199, DISTRICT 12, SECTION 3
CITY OF DALTON
PARCEL: 12-199-27-057
WHITFIELD COUNTY, GEORGIA
N 34.775745°, W 84.977352°
SITE AREA: ±2.64 ACRES
DISTURBED AREA: ±0.90 ACRES

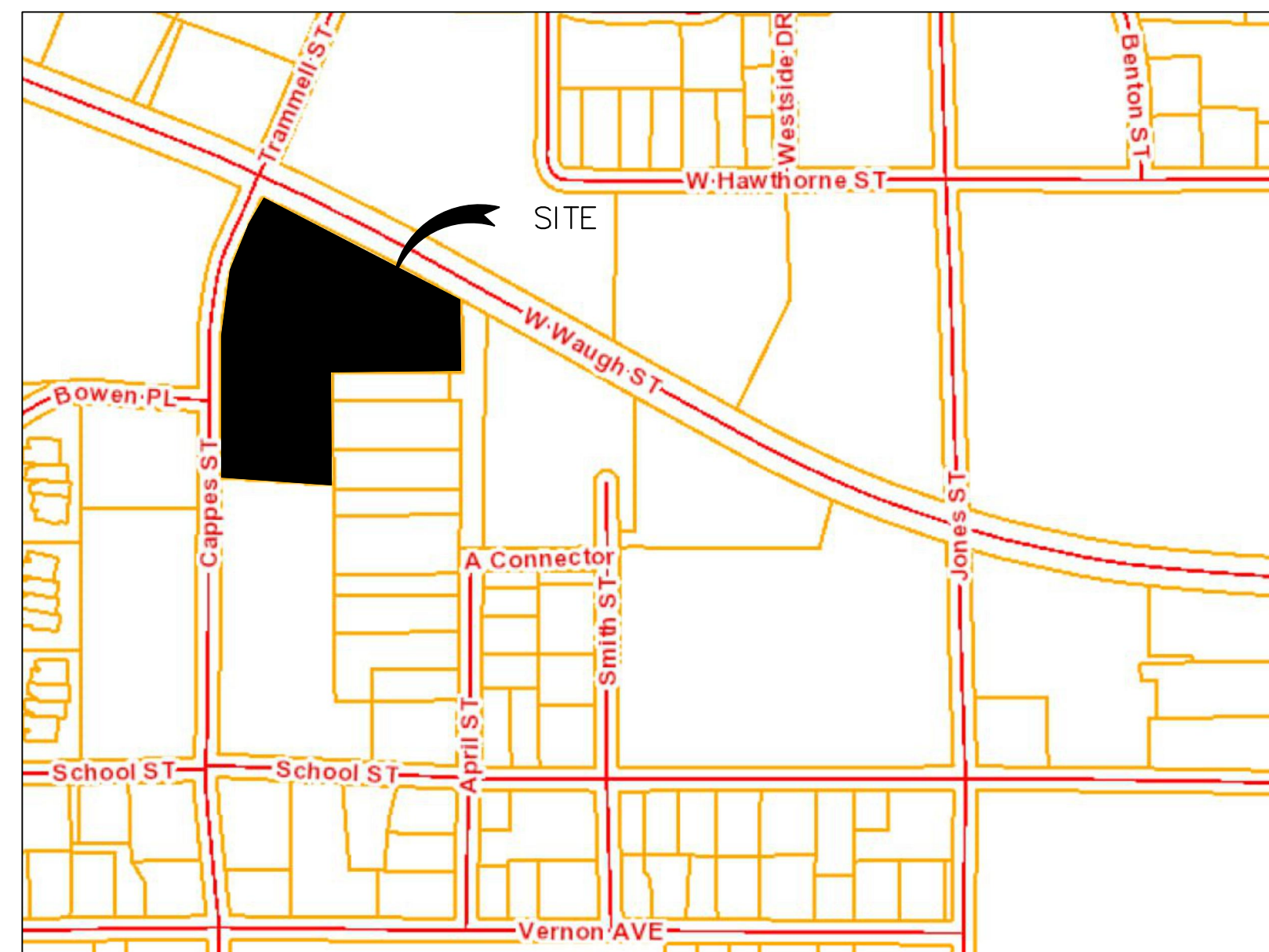

VICINITY MAP
NTS

DESIGN PROFESSIONAL'S CERTIFICATION

1. I CERTIFY THAT THE PERMITTEE'S EROSION, SEDIMENTATION AND POLLUTION CONTROL PLAN PROVIDES FOR AN APPROPRIATE AND COMPREHENSIVE SYSTEM OF BEST MANAGEMENT PRACTICES REQUIRED BY THE GEORGIA WATER QUALITY CONTROL ACT AND THE DOCUMENT "MANUAL FOR EROSION AND SEDIMENT CONTROL IN GEORGIA" (MANUAL) PUBLISHED BY THE GEORGIA SOIL AND WATER CONSERVATION COMMISSION AS OF JANUARY 1 OF THE YEAR IN WHICH THE LAND-DISTURBING ACTIVITY WAS PERMITTED, PROVIDES FOR THE SAMPLING OF THE RECEIVING WATER(S) OR THE SAMPLING OF THE STORM WATER OUTFALLS AND THAT THE DESIGNED SYSTEM OF BEST MANAGEMENT PRACTICES AND SAMPLING METHODS IS EXPECTED TO MEET THE REQUIREMENTS CONTAINED IN THE GENERAL NPDES PERMIT NO. GAR 100001.
2. I CERTIFY UNDER PENALTY OF LAW THAT THIS PLAN WAS PREPARED AFTER A SITE VISIT TO THE LOCATIONS DESCRIBED HEREIN BY MYSELF OR MY AUTHORIZED AGENT, UNDER MY SUPERVISION.
3. GEORGIA'S 305(b)/303(d) LIST DOCUMENTS HAVE BEEN CONSULTED.

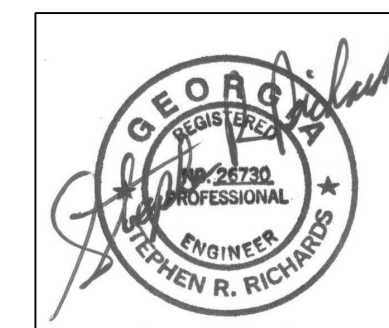

STEPHEN R. RICHARDS, PE
GSWCC LEVEL II CERTIFICATION NO. 8688

10/20/25
DATE

THIS PROJECT IS DESIGNED TO BE IN COMPLIANCE WITH THE GEORGIA GENERAL PERMIT NO. GAR100001 AUTHORIZATION TO DISCHARGE UNDER THE NATIONAL POLLUTANT DISCHARGE ELIMINATION SYSTEM WITH CONSTRUCTION ACTIVITY FOR STAND ALONE CONSTRUCTION PROJECTS EFFECTIVE AUGUST 1, 2018 AND THE MANUAL FOR EROSION AND SEDIMENT CONTROL IN GEORGIA, EFFECTIVE JANUARY 1, 2016.

OWNER/DEVELOPER:
NORTHWEST GEORGIA
REGIONAL LIBRARY SYSTEM
310 CAPPES STREET
DALTON, GA 30720

PRIMARY PERMITTEE:
XXX

24 HOUR LOCAL CONTACT RESPONSIBLE FOR
EROSION, SEDIMENTATION AND POLLUTION

CONTROLS:
XXX

SHEET INDEX

- C0 COVER SHEET
- C1 INITIAL PHASE SOIL EROSION, SEDIMENTATION & POLLUTION CONTROL PLAN
- C2 INTERMEDIATE A SOIL EROSION, SEDIMENTATION & POLLUTION CONTROL PLAN
- C3 INTERMEDIATE B SOIL EROSION, SEDIMENTATION & POLLUTION CONTROL PLAN
- C4 FINAL PHASE SOIL EROSION, SEDIMENTATION & POLLUTION CONTROL PLAN
- C5 SOIL EROSION, SEDIMENTATION & POLLUTION CONTROL DETAILS
- C6 SOIL EROSION, SEDIMENTATION & POLLUTION CONTROL DETAILS
- C7 SOIL EROSION, SEDIMENTATION & POLLUTION CONTROL DETAILS
- C8 EXISTING CONDITIONS & DEMOLITION PLAN
- C9 SITE PLAN
- C10 GRADING & DRAINAGE PLAN
- C11 CONSTRUCTION DETAILS



RICHARDS & ASSOCIATES ENGINEERING, INC.
CIVIL ENGINEERING + LAND PLANNING
P.O. BOX 220, CHATSWORTH, GA 30705
(706) 616-5906

© RICHARDS & ASSOC. ENGINEERING, INC.



Know what's below.
Call before you dig.

PHASE #3
DALTON WHITFIELD COUNTY PUBLIC LIBRARY
READING PAVILION
310 CAPPES STREET. DALTON, GA

JOB NO. RAE 24-018
DATE 10/20/25
DRAWN BY SRR
REVISIONS

DRAWING TITLE

CIVIL
COVER SHEET

SHEET NO.

C0

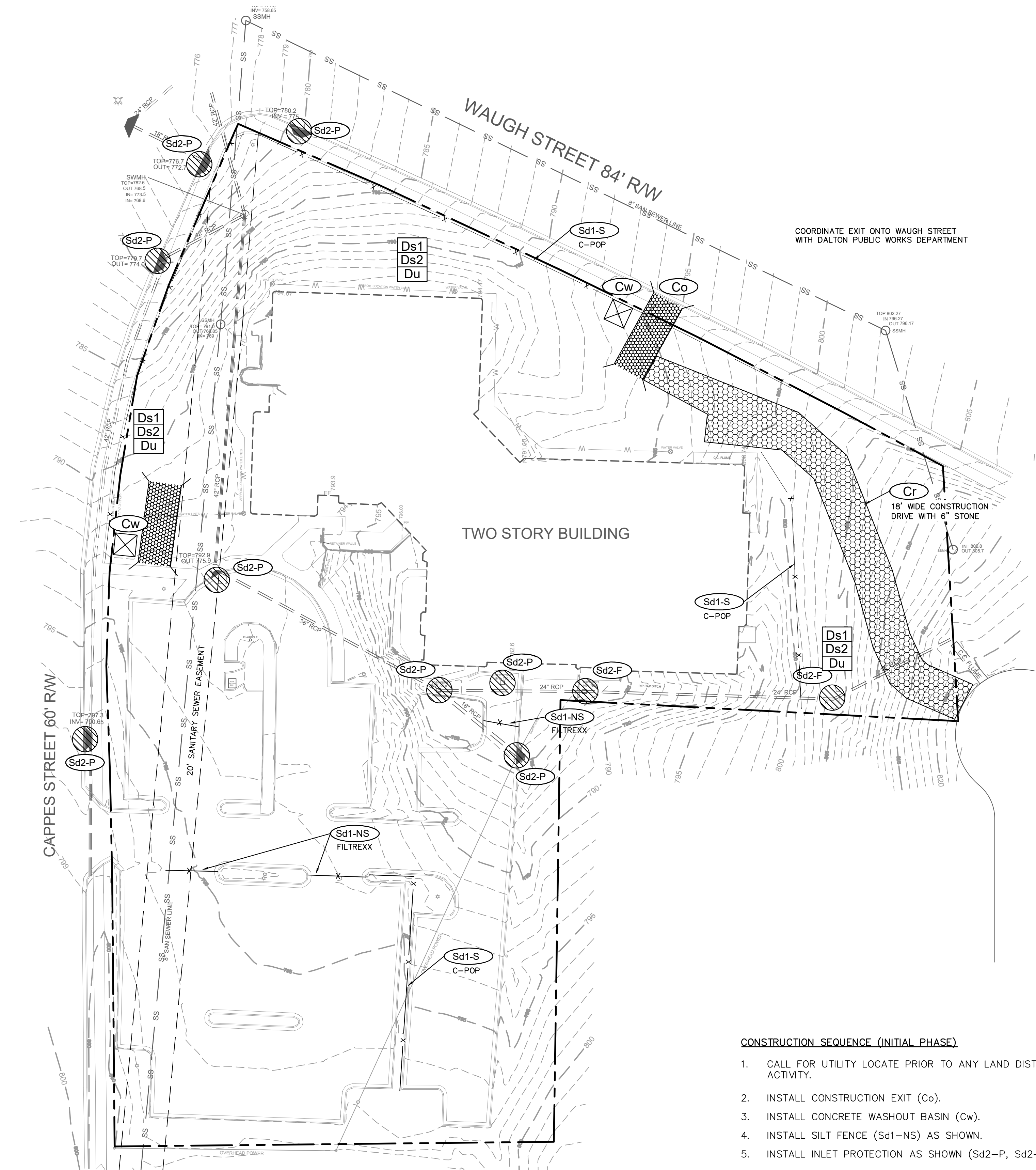
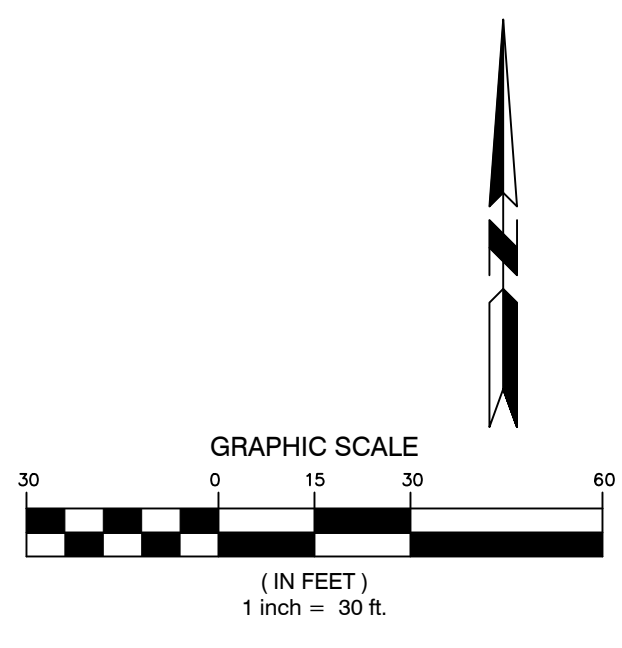

CONSTRUCTION SEQUENCE (INITIAL PHASE)

1. CALL FOR UTILITY LOCATE PRIOR TO ANY LAND DISTURBING ACTIVITY.
2. INSTALL CONSTRUCTION EXIT (Co).
3. INSTALL CONCRETE WASHOUT BASIN (Cw).
4. INSTALL SILT FENCE (Sd1-NS) AS SHOWN.
5. INSTALL INLET PROTECTION AS SHOWN (Sd2-P, Sd2-F).

NOTE: AT THE END OF EACH DAY, CONSTRUCT A SAFETY FENCE AROUND ALL SEDIMENT BASINS OR TRAPS, DITCHES, TRENCHES, HOLES, ETC. WITH 2:1 OR STEEPER SLOPES AND A DEPTH GREATER THAN 24".

EROSION CONTROL LEGEND

Cd	CHECKDAM	
Ch	CHANNEL STABILIZATION	Ch-(typ)
Co	CONSTRUCTION EXIT	
Di	DIVERSION DITCH	Di
Fr	STONE FILTER RING	
Rt	RETROFITTING	
Sd1	SEDIMENT BARRIER	
Sd2	INLET SEDIMENT TRAP	
Sd3	TEMPORARY SEDIMENT BASIN	
St	STORM DRAIN OUTLET PROTECTION	
Su	SURFACE ROUGHENING	
Sd4	TEMPORARY SEDIMENT TRAP	
Ss	EROSION CONTROL MATTING	
Bf	BUFFER ZONE	
Ds1	DISTURBED AREA STABILIZATION WITH MULCHING ONLY	
Ds2	DISTURBED AREA STABILIZATION WITH TEMPORARY SEEDING	
Ds3	DISTURBED AREA STABILIZATION WITH PERMANENT VEGETATION	
Pm	POLYACRYLAMIDE	PAM
Du	DUST CONTROL	



Northwest Georgia Regional Library System
Dalton-Whitfield • Calhoun-Gordon • Chatsworth-Murray

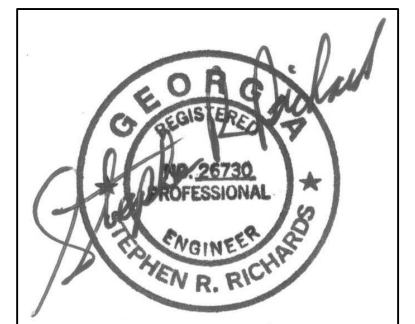
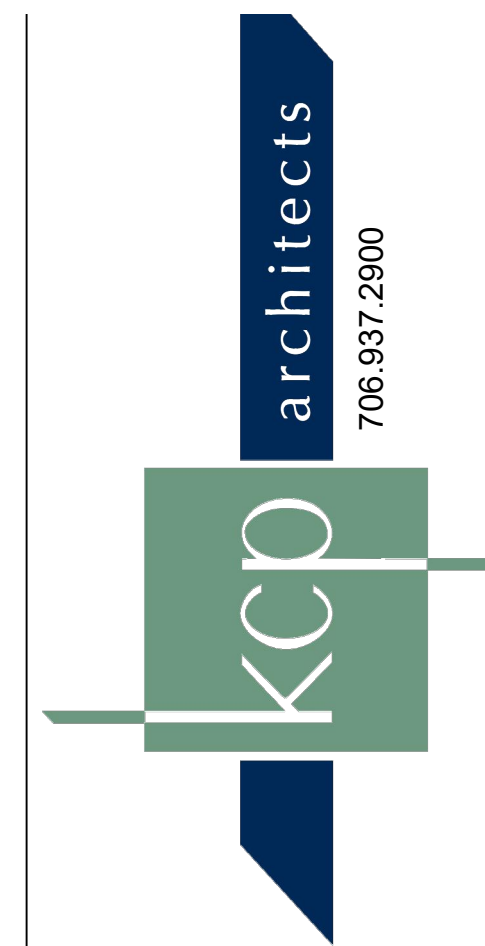

GA PROFESSIONAL ENGINEER NO. 26730
LEVEL II CERTIFIED DESIGN
PROFESSIONAL NO. 8688

PHASE #3
DALTON WHITFIELD COUNTY PUBLIC LIBRARY
READING PAVILION
310 CAPPES STREET. DALTON, GA

JOB NO.	RAE 24-018
DATE	10/20/25
DRAWN BY	SRR
REVISIONS	

DRAWING TITLE
INTERMEDIATE A
SOIL EROSION
SEDIMENTATION
AND POLLUTION
CONTROL PLAN

SHEET NO.

C2



RICHARDS & ASSOCIATES ENGINEERING, INC.
CIVIL ENGINEERING + LAND PLANNING
P.O. BOX 220, CHATSWORTH, GA 30705
(706) 616-5906

© RICHARDS & ASSOC. ENGINEERING, INC.

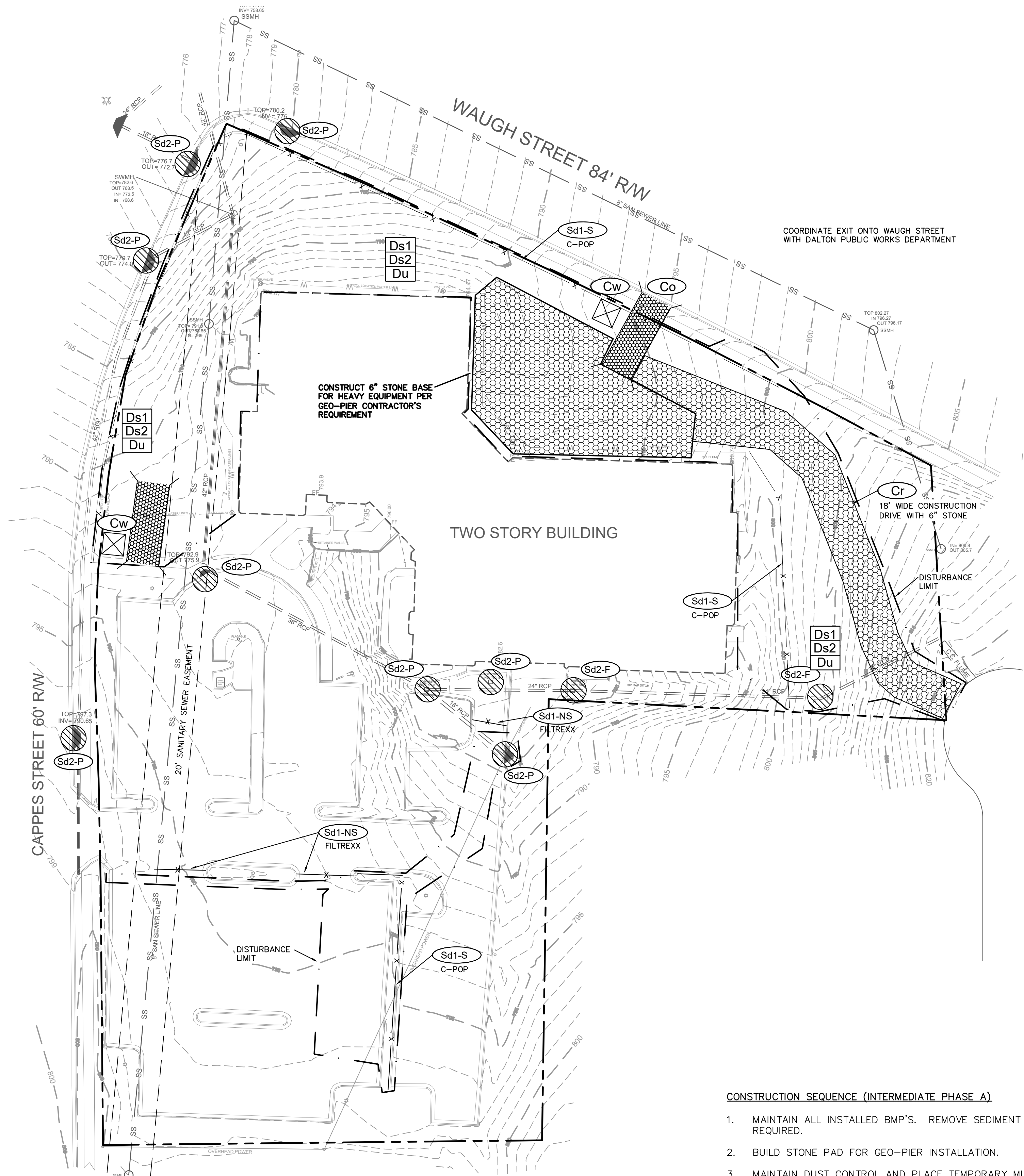

CONSTRUCTION SEQUENCE (INTERMEDIATE PHASE A)

1. MAINTAIN ALL INSTALLED BMP'S. REMOVE SEDIMENT AS REQUIRED.
2. BUILD STONE PAD FOR GEO-PIER INSTALLATION.
3. MAINTAIN DUST CONTROL AND PLACE TEMPORARY MULCH AND/OR GRASSING AS NEEDED.

NOTE: AT THE END OF EACH DAY, CONSTRUCT A SAFETY FENCE AROUND ALL SEDIMENT BASINS OR TRAPS, DITCHES, TRENCHES, HOLES, ETC. WITH 2:1 OR STEEPER SLOPES AND A DEPTH GREATER THAN 24".

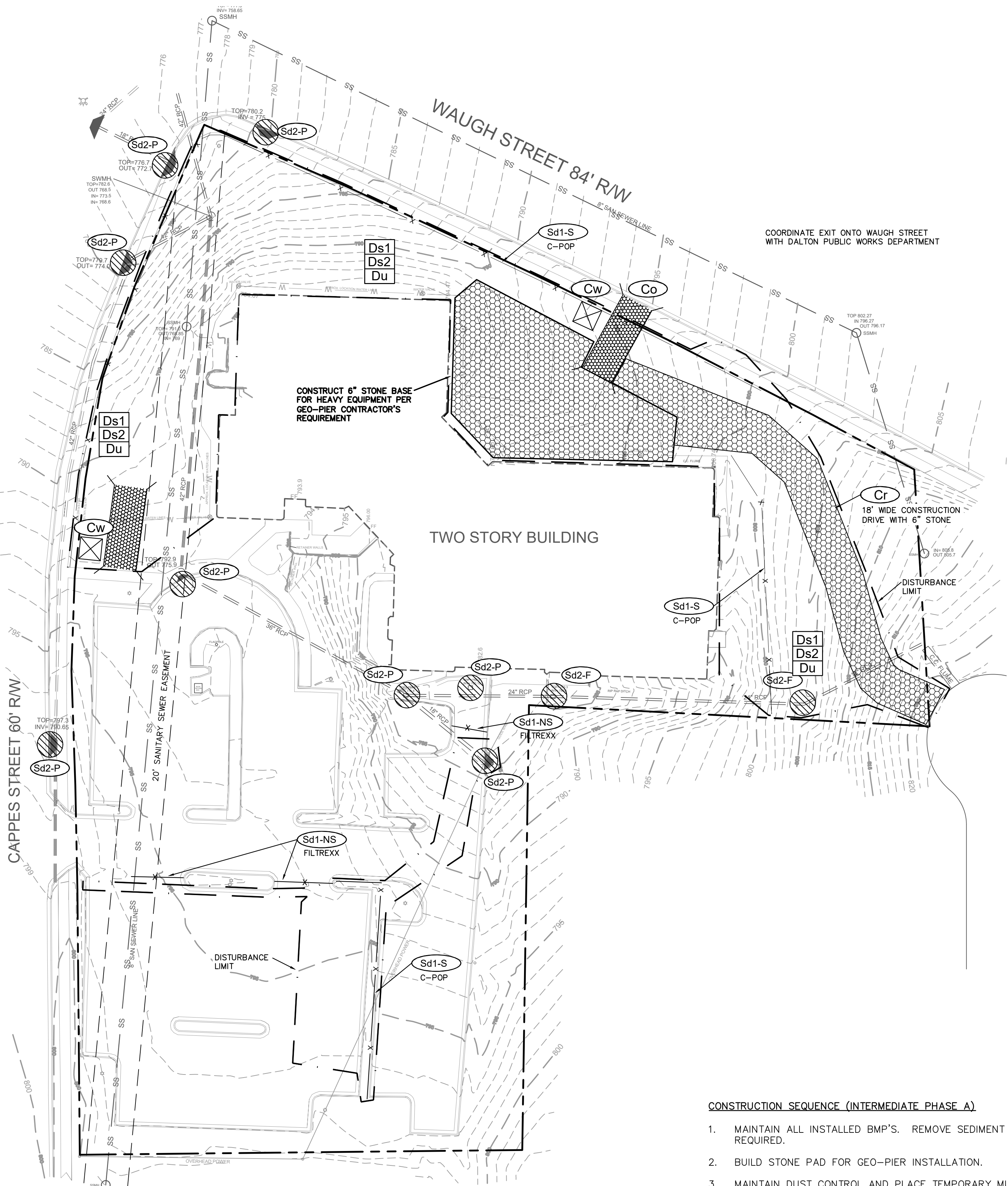
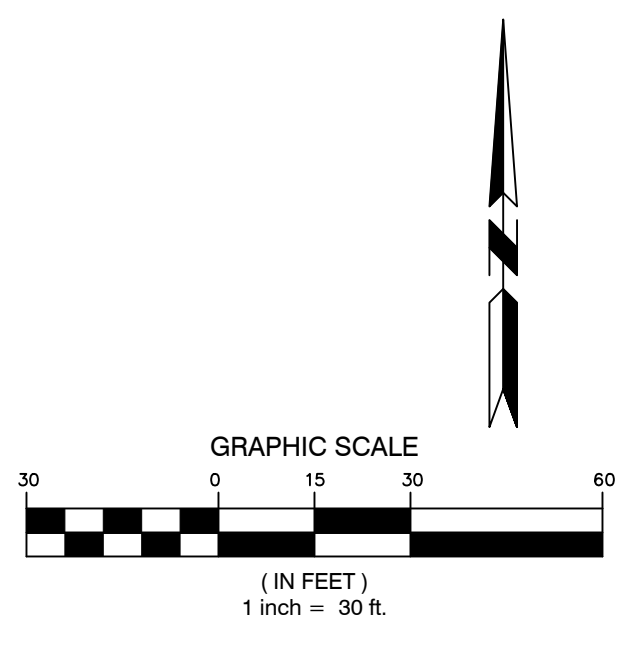

CONSTRUCTION SEQUENCE (INTERMEDIATE PHASE A)

1. MAINTAIN ALL INSTALLED BMP'S. REMOVE SEDIMENT AS REQUIRED.
2. BUILD STONE PAD FOR GEO-PIER INSTALLATION.
3. MAINTAIN DUST CONTROL AND PLACE TEMPORARY MULCH AND/OR GRASSING AS NEEDED.

NOTE: AT THE END OF EACH DAY, CONSTRUCT A SAFETY FENCE AROUND ALL SEDIMENT BASINS OR TRAPS, DITCHES, TRENCHES, HOLES, ETC. WITH 2:1 OR STEEPER SLOPES AND A DEPTH GREATER THAN 24".

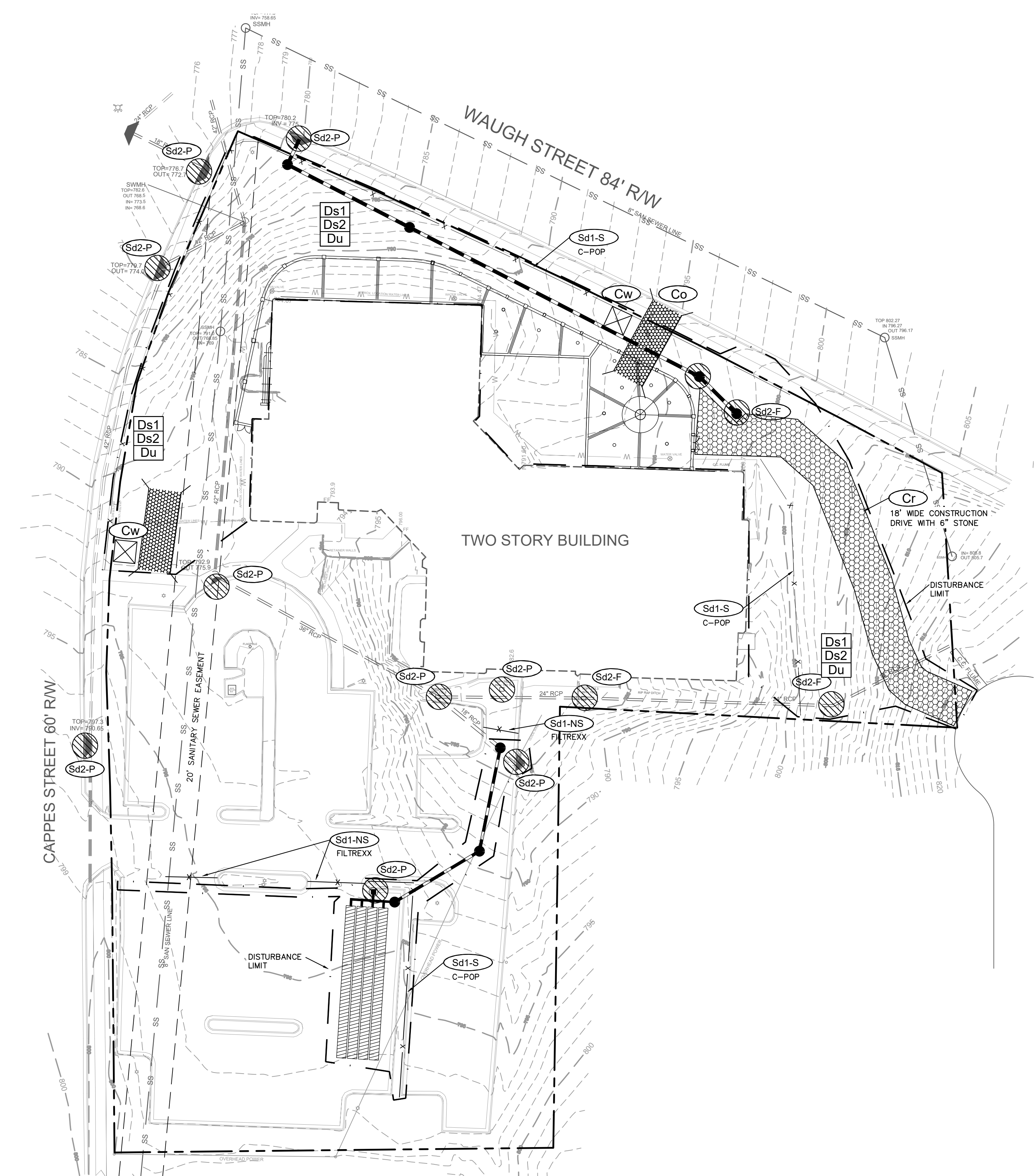
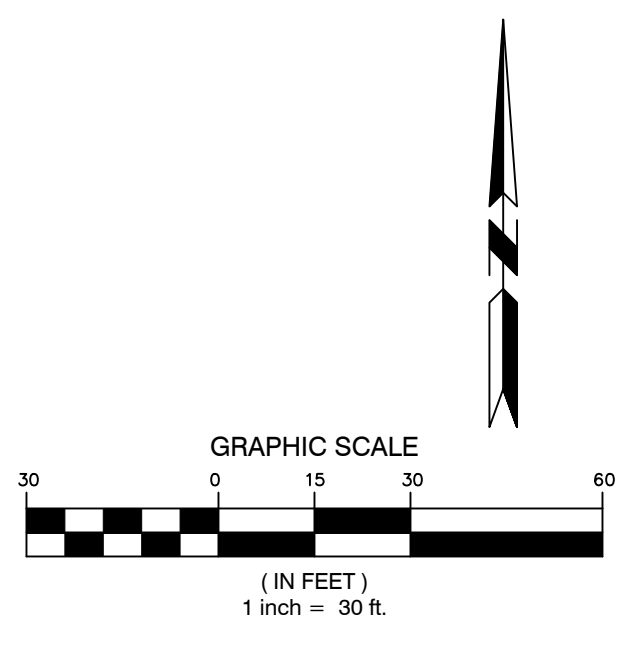

CONSTRUCTION SEQUENCE (INTERMEDIATE PHASE B)

1. MAINTAIN ALL INSTALLED BMP'S. REMOVE SEDIMENT AS REQUIRED.
2. INSTALL STORM SEWER.
3. CONSTRUCT BUILDING.
4. MAINTAIN DUST CONTROL AND PLACE TEMPORARY MULCH AND/OR GRASSING AS NEEDED.

NOTE: AT THE END OF EACH DAY, CONSTRUCT A SAFETY FENCE AROUND ALL SEDIMENT BASINS OR TRAPS, DITCHES, TRENCHES, HOLES, ETC. WITH 2:1 OR STEEPER SLOPES AND A DEPTH GREATER THAN 24".

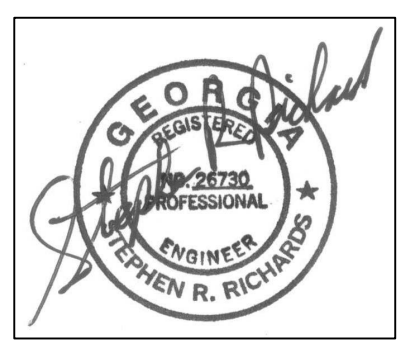

GA PROFESSIONAL ENGINEER NO. 26730
LEVEL II CERTIFIED DESIGN
PROFESSIONAL NO. 8688

PHASE #3
DALTON WHITFIELD COUNTY PUBLIC LIBRARY
READING PAVILION
310 CAPPES STREET. DALTON, GA

JOB NO.	RAE 24-018
DATE	10/20/25
DRAWN BY	SRR
REVISIONS	

DRAWING TITLE
INTERMEDIATE B
SOIL EROSION
SEDIMENTATION
AND POLLUTION
CONTROL PLAN
SHEET NO.

C3

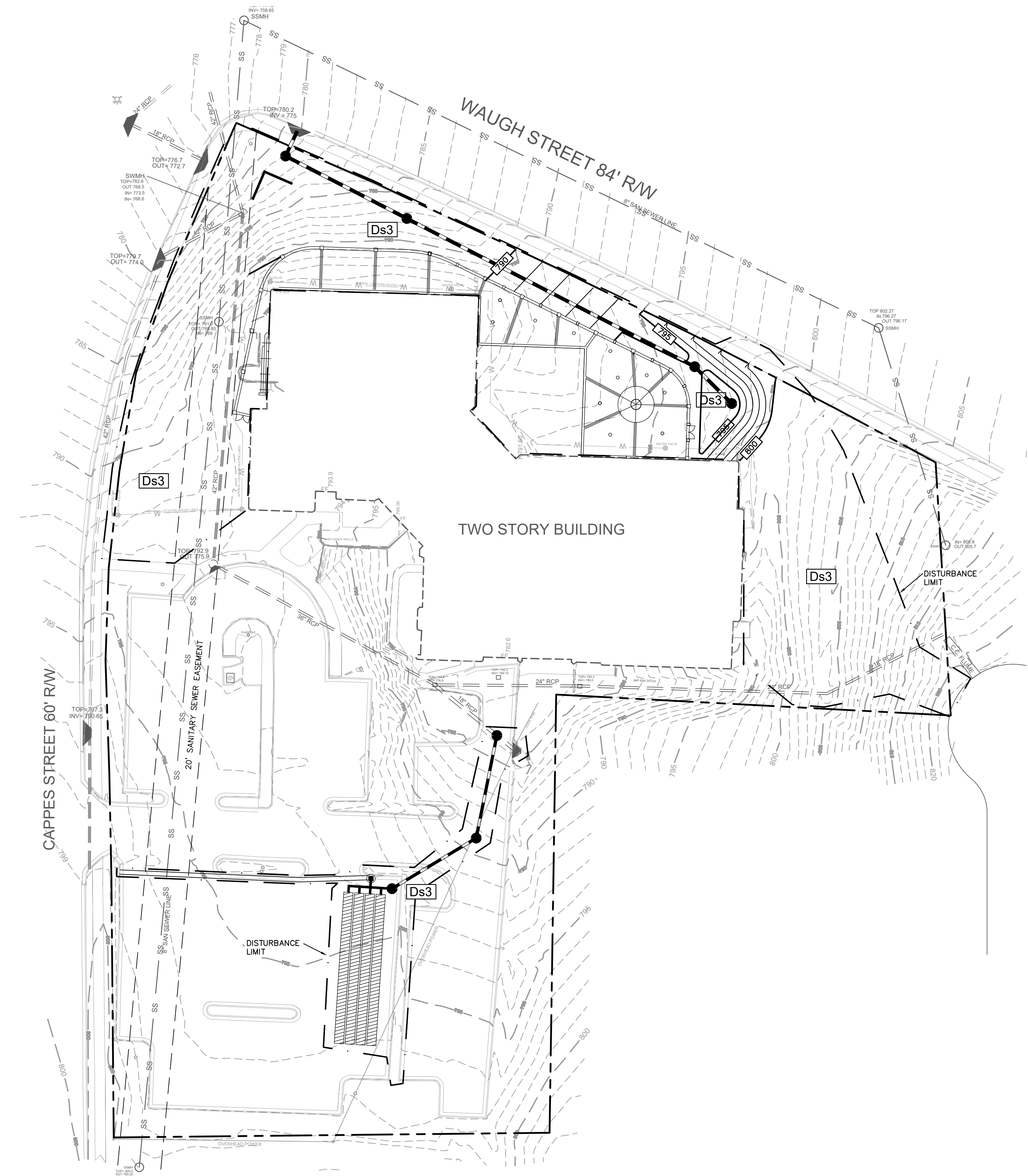
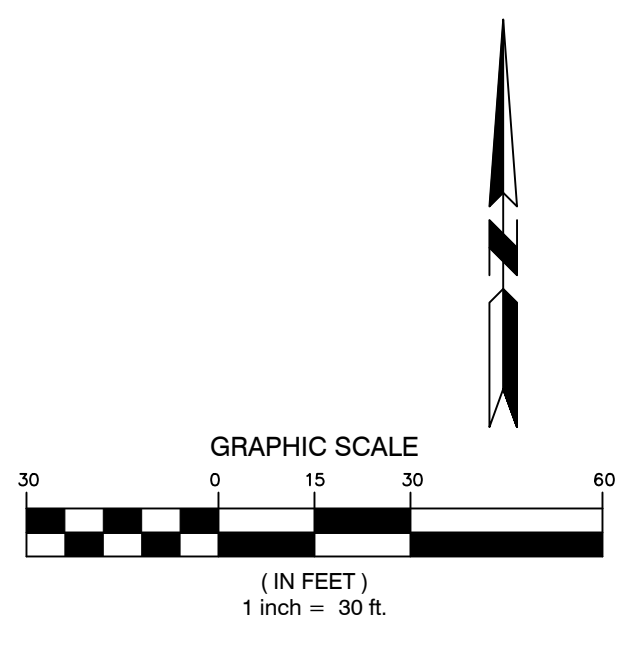

CONSTRUCTION SEQUENCE (FINAL PHASE)

1. MAINTAIN ALL INSTALLED BMP'S. REMOVE SEDIMENT AS REQUIRED. MAINTAIN MONITORING PROGRAM.
2. COMPLETE GRADING OPERATIONS AND STABILIZE ALL DISTURBED AREAS WITH THE APPROPRIATE PERMANENT VEGETATION OR OTHER SURFACE TREATMENT. INSTALL MATTING ON ALL POND SLOPES AND 4" OF STRAW ON ALL OTHER DISTURBED AREAS.
3. REMOVE CONCRETE WASHOUT BASIN. STABILIZE THE AREA WITH THE APPROPRIATE PERMANENT VEGETATION.
4. ONCE FINAL STABILIZATION HAS BEEN ACHIEVED IN ALL OTHER AREAS, REMOVE PERIMETER SILT FENCE AND CONSTRUCTION EXITS. STABILIZE THESE AREAS WITH THE APPROPRIATE PERMANENT VEGETATION. BY DEFINITION, FINAL STABILIZATION MEANS THAT ALL SOIL DISTURBING ACTIVITIES AT THE SITE HAVE BEEN COMPLETED, AND THAT FOR UNPAVED AREAS AND AREAS NOT COVERED BY PERMANENT STRUCTURES AND AREAS LOCATED OUTSIDE THE WASTE DISPOSAL LIMITS OF A LANDFILL CELL THAT HAS BEEN CERTIFIED BY EPD FOR WASTE DISPOSAL, 100% OF THE SOIL SURFACE IS UNIFORMLY COVERED IN PERMANENT VEGETATION WITH A DENSITY OF 70% OR GREATER, OR LANDSCAPED ACCORDING TO THE PLAN (UNIFORMLY COVERED WITH LANDSCAPING MATERIALS IN PLANNED LANDSCAPED AREAS), OR EQUIVALENT PERMANENT STABILIZATION MEASURES AS DEFINED IN THE MANUAL (EXCLUDING A CROP OF ANNUAL VEGETATION AND SEEDING OF TARGET CROP PERENNIALS APPROPRIATE FOR THE REGION).

NOTE: AT THE END OF EACH DAY, CONSTRUCT A SAFETY FENCE AROUND ALL SEDIMENT BASINS OR TRAPS, DITCHES, TRENCHES, HOLES, ETC. WITH 2:1 OR STEEPER SLOPES AND A DEPTH GREATER THAN 24".

	MONTHS FROM START OF CONSTRUCTION					
	1	2	3	4	5	6
CLEARING FOR BMPs	█					
SEDIMENT CONTROL	█	█	█	█	█	█
MAINTAIN EROSION CONTROL	█	█	█	█	█	█
EARTHWORK		█	█	█		
BUILDING CONSTRUCTION			█	█	█	█
TEMPORARY GRASSING		█	█	█	█	█
FINAL GRASS LANDSCAPE					█	█
PAVING						█
REMOVAL OF TEMPORARY BMPs						█

CONSTRUCTION SCHEDULED TO BEGIN ON XX AND BE COMPLETED ON OR BEFORE XX

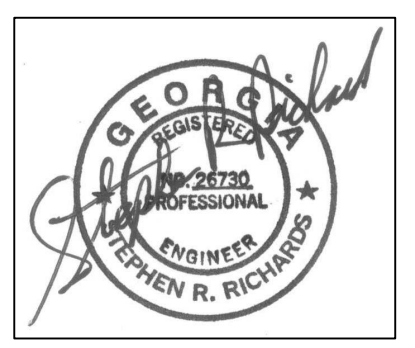
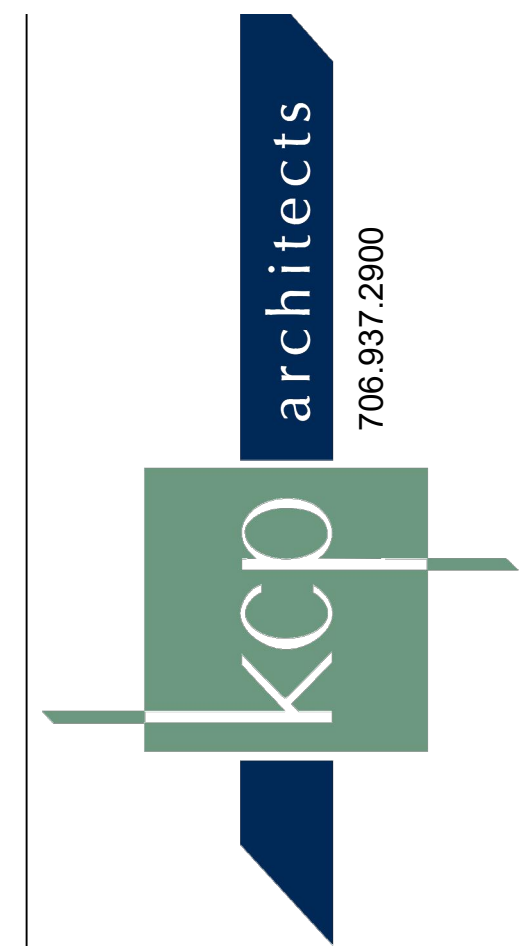

GA PROFESSIONAL ENGINEER NO. 26730
LEVEL II CERTIFIED DESIGN
PROFESSIONAL NO. 8688

PHASE #3
 DALTON WHITFIELD COUNTY PUBLIC LIBRARY
READING PAVILION
 310 CAPPES STREET. DALTON, GA



RICHARDS & ASSOCIATES ENGINEERING, INC.
 CIVIL ENGINEERING + LAND PLANNING
 P.O. BOX 220, CHATSWORTH, GA 30705
 (706) 616-5906

JOB NO. RAE 24-018
 DATE 10/20/25
 DRAWN BY SRR
 REVISIONS

DRAWING TITLE
**FINAL PHASE
 SOIL EROSION
 SEDIMENTATION
 AND POLLUTION
 CONTROL PLAN**

SHEET NO.

C4

CRUSHED STONE CONSTRUCTION EXIT

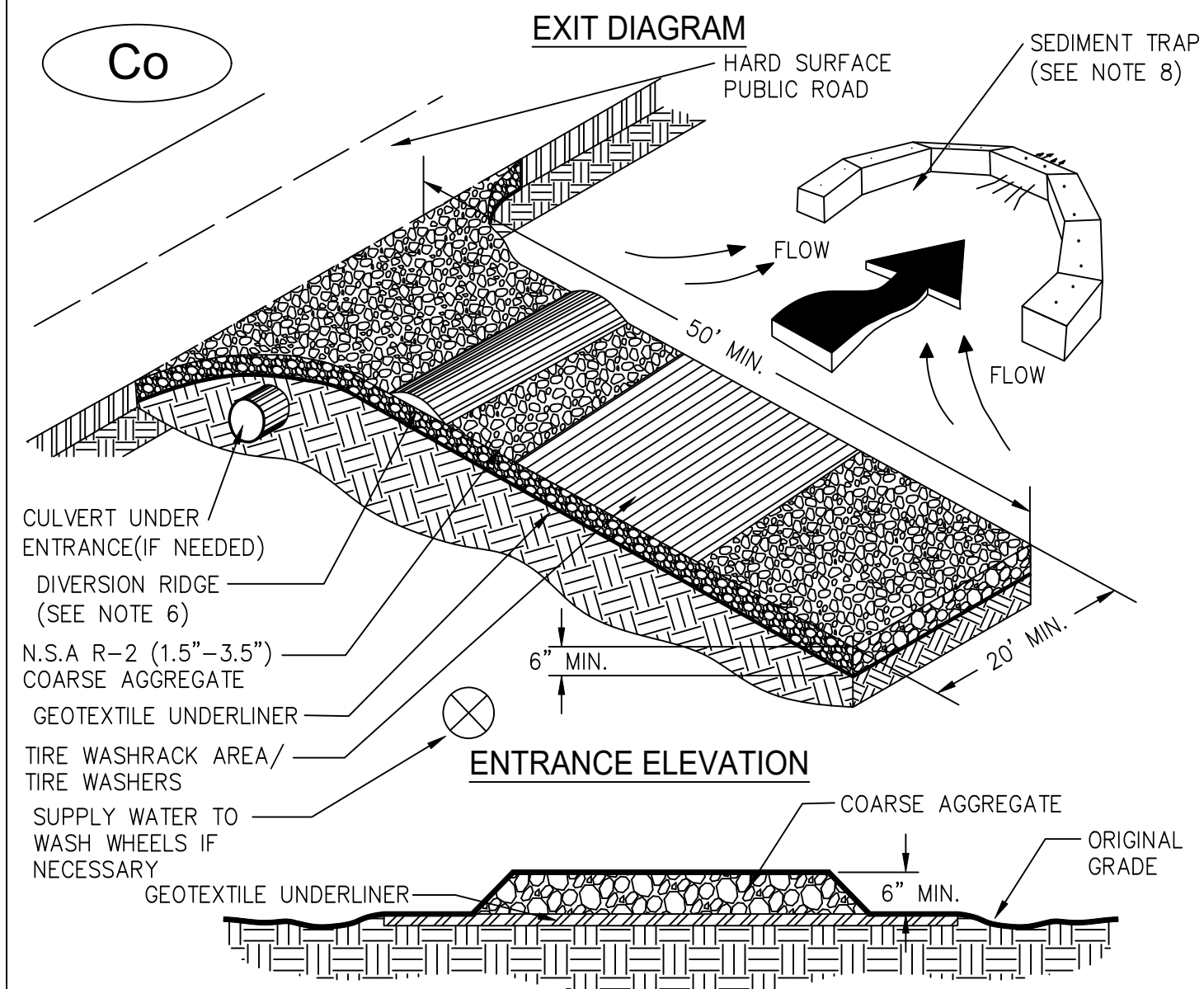

- NOTES:**
1. AVOID LOCATING ON STEEP SLOPES OR AT CURVES ON PUBLIC ROADS.
 2. REMOVE ALL VEGETATION AND OTHER UNSUITABLE MATERIAL FROM THE FOUNDATION AREA, GRADE, AND CROWN FOR POSITIVE DRAINAGE.
 3. AGGREGATE SIZE SHALL BE IN ACCORDANCE WITH NATIONAL STONE ASSOCIATION R-2 (1.5"-3.5" STONE).
 4. GRAVEL PAD SHALL HAVE A MINIMUM THICKNESS OF 6".
 5. PAD WIDTH SHALL BE EQUAL FULL WIDTH AT ALL POINTS OF VEHICULAR EGRESS, BUT NO LESS THAN 20'.
 6. A DIVERSION RIDGE SHOULD BE CONSTRUCTED WHEN GRADE TOWARD PAVED AREA IS GREATER THAN 2%.
 7. INSTALL PIPE UNDER THE ENTRANCE IF NEEDED TO MAINTAIN DRAINAGE DITCHES.
 8. WHEN WASHING IS REQUIRED, IT SHOULD BE DONE ON AN AREA STABILIZED WITH CRUSHED STONE THAT DRAINS INTO AN APPROVED SEDIMENT TRAP OR SEDIMENT BASIN (DIVERT ALL SURFACE RUNOFF AND DRAINAGE FROM THE ENTRANCE TO A SEDIMENT CONTROL DEVICE).
 9. WASHRACKS AND/OR TIRE WASHERS MAY BE REQUIRED DEPENDING ON SCALE AND CIRCUMSTANCE. IF NECESSARY, WASHRACK DESIGN MAY CONSIST OF ANY MATERIAL SUITABLE FOR TRUCK TRAFFIC THAT REMOVE MUD AND DIRT.
 10. MAINTAIN AREA IN A WAY THAT PREVENTS TRACKING AND/OR FLOW OF MUD ONTO PUBLIC RIGHTS-OF-WAYS. THIS MAY REQUIRE TOP DRESSING, REPAIR AND/OR CLEANOUT OF ANY MEASURES USED TO TRAP SEDIMENT.

TYPICAL INSTALLATION GUIDELINES FOR ROLLED EROSION CONTROL PRODUCTS (RECP)

BLANKET AND MATTING CROSS-SECTIONS

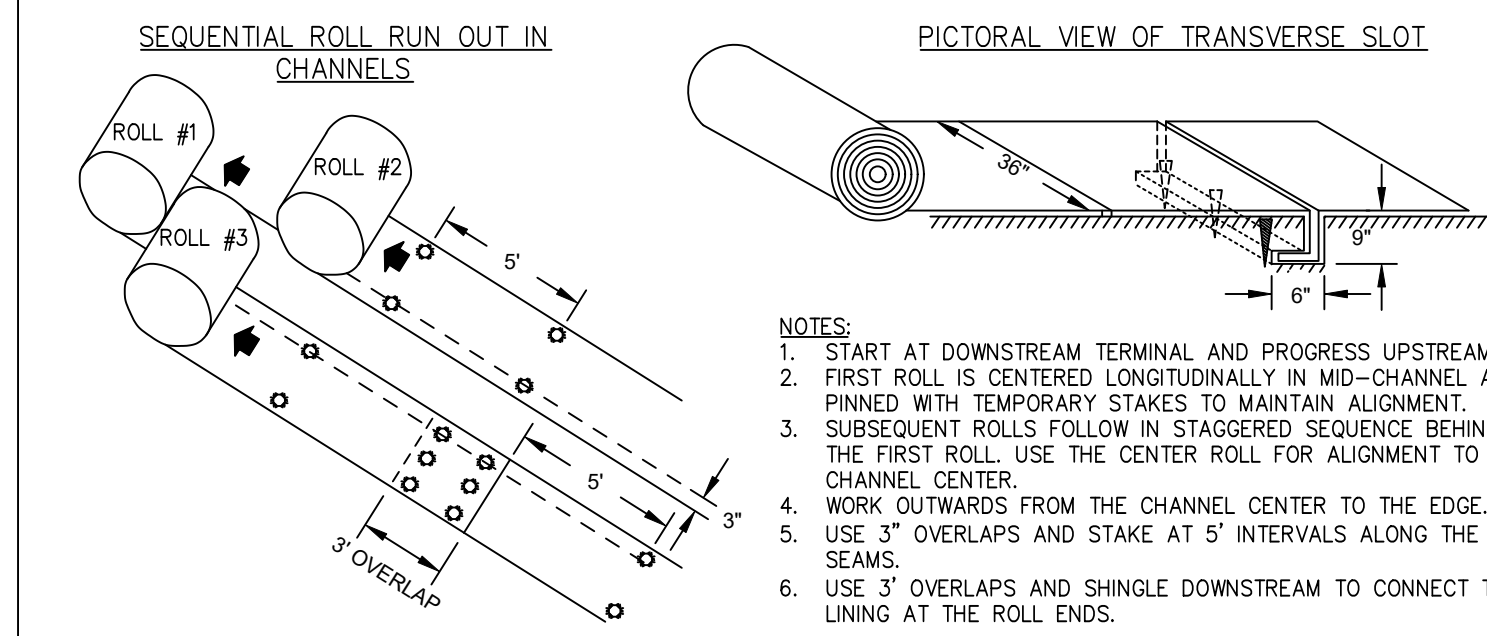
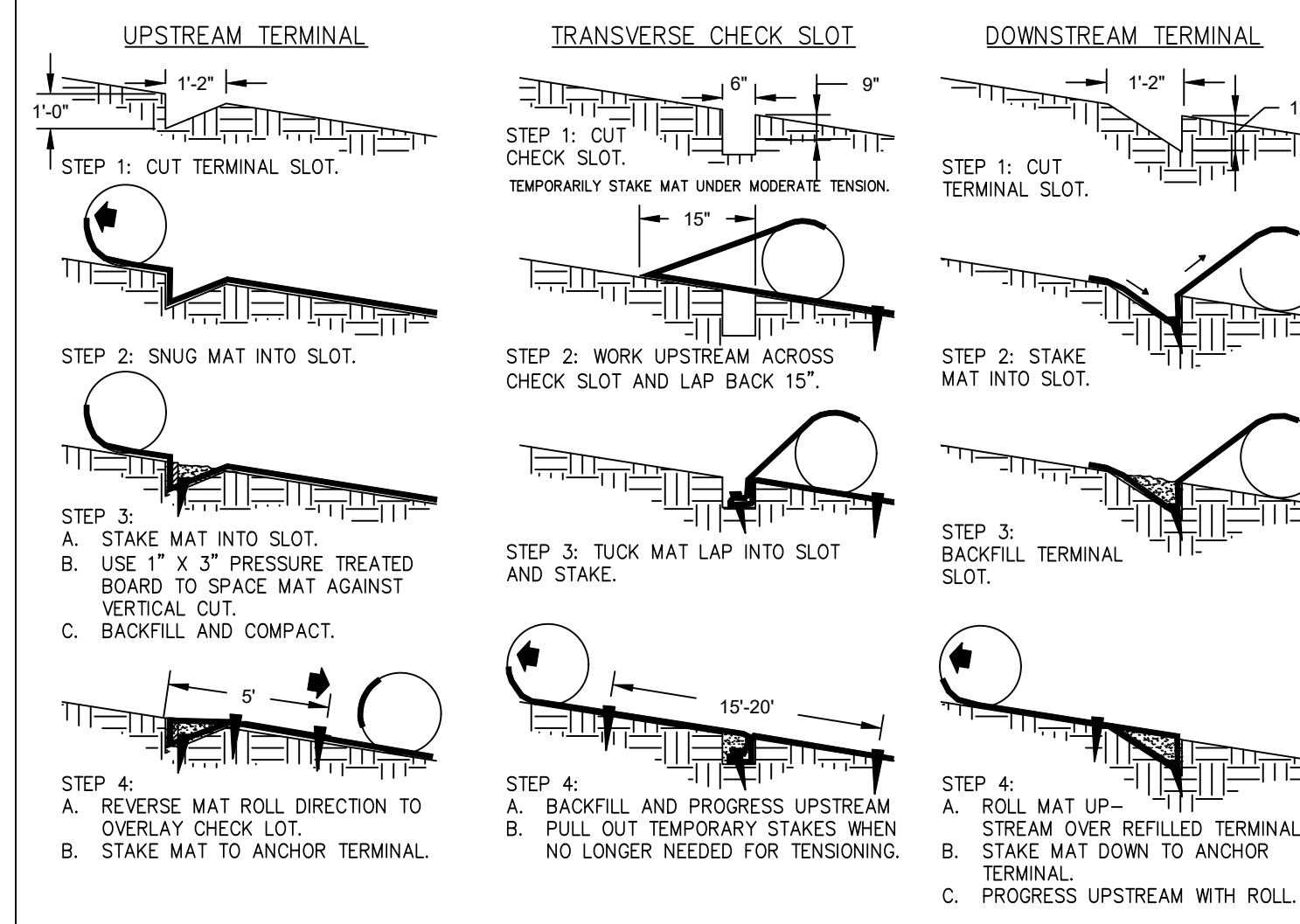

SILT FENCE - TYPE NON-SENSITIVE

SIDE VIEW

Sd1-NS

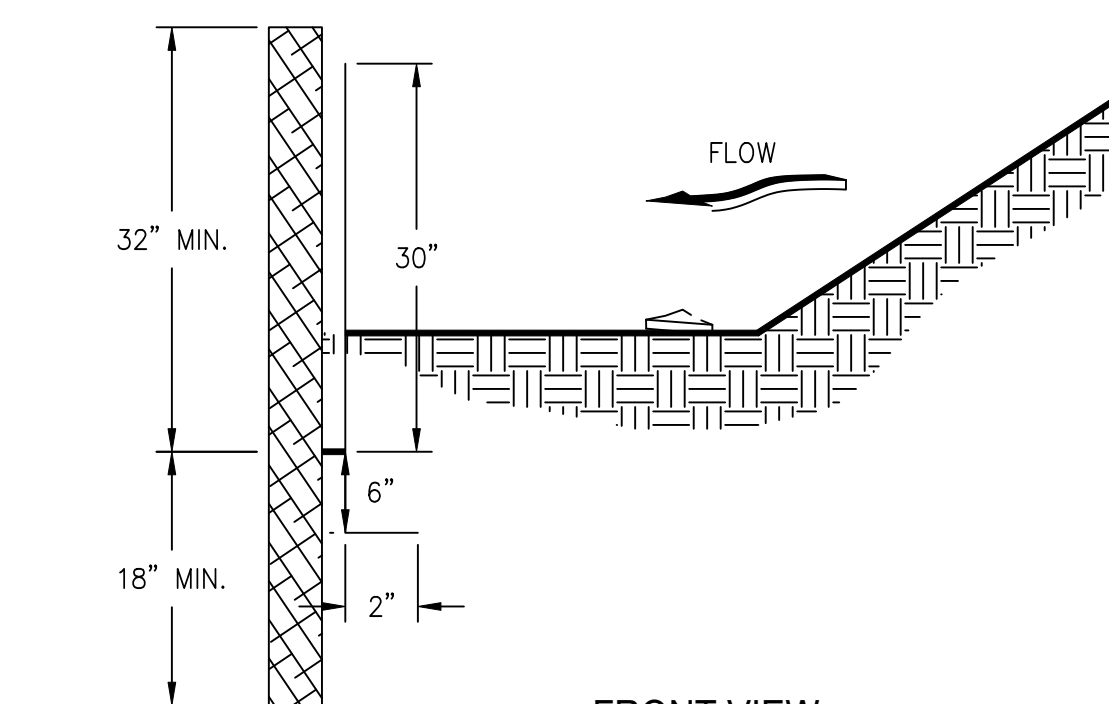

FRONT VIEW

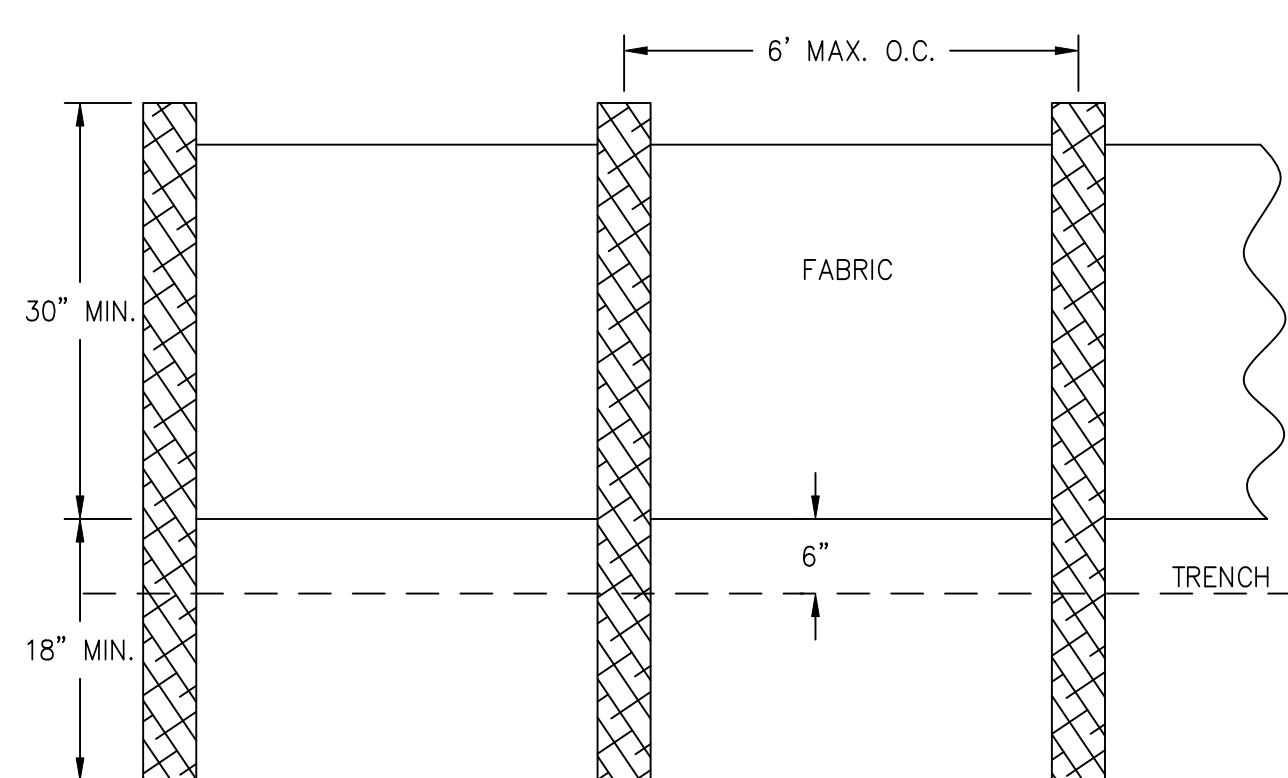

- NOTES:**
1. USE STEEL OR WOOD POSTS OR AS SPECIFIED BY THE EROSION, SEDIMENTATION, AND POLLUTION CONTROL PLAN.
 2. HEIGHT (*) IS TO BE SHOWN ON THE EROSION, SEDIMENTATION, AND POLLUTION CONTROL PLAN.

SODDED WATERWAYS

SOD DIRECTIONS

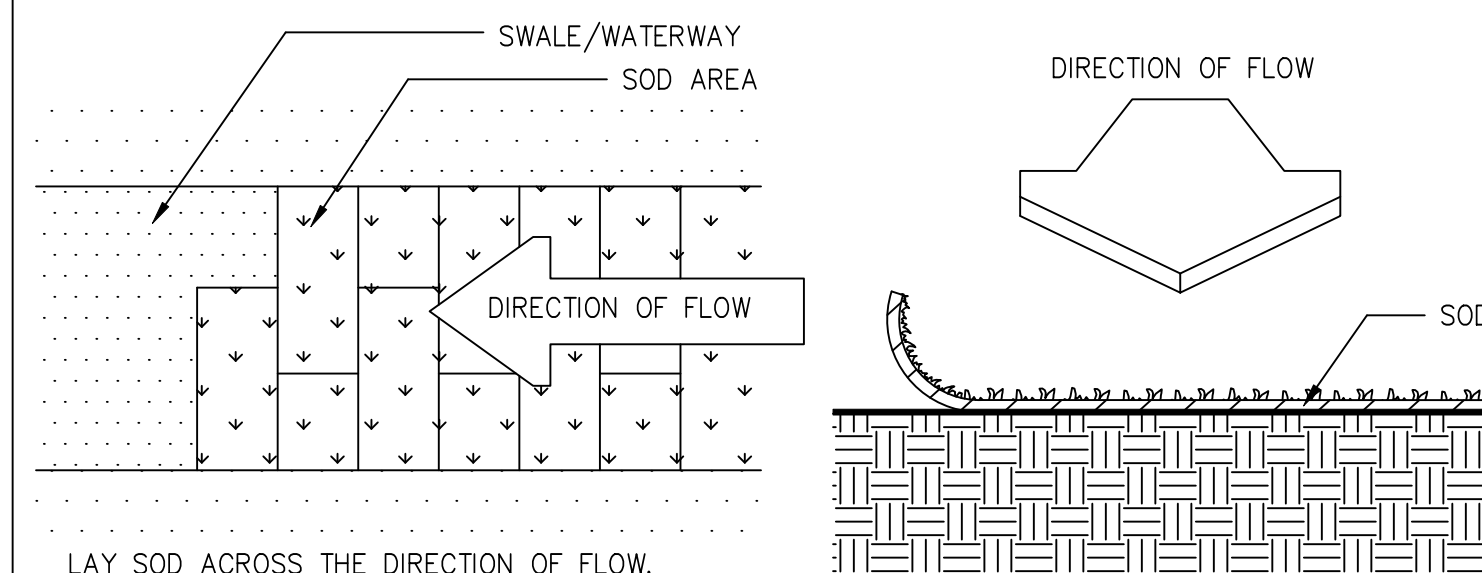

NETTING DIRECTIONS

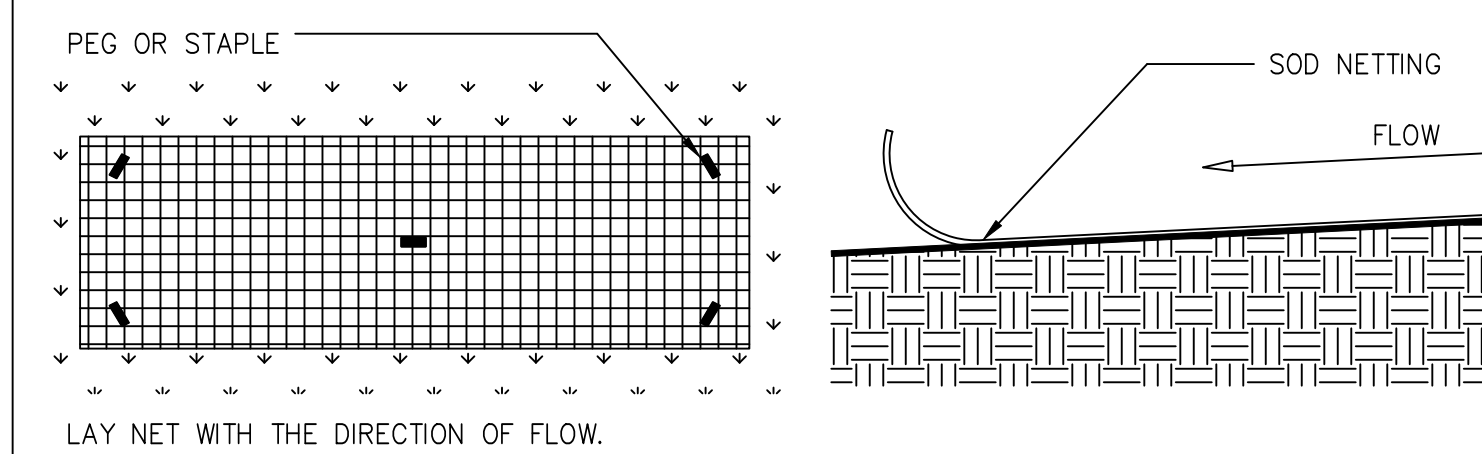

PEG DETAIL

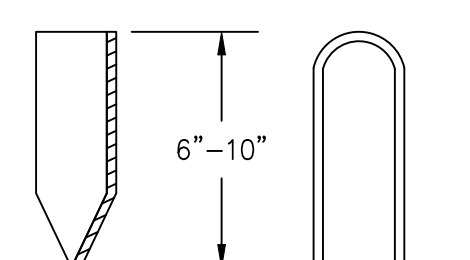

IN CRITICAL AREAS, SECURE SOD WITH NETTING USING STAPLES.
USE PEGS OR STAPLES TO FASTEN SOD FIRMLY -- AT THE ENDS OF STRIPS AND IN THE CENTER, OR EVERY 3-4 FEET IF THE STRIPS ARE LONG. WHEN READY TO MOW, DRIVE PEGS OR STAPLES FLUSH WITH THE GROUND.

SOD MAINTENANCE AND INSTALLATION

SOD LAYING AND PREPARATION

LAY SOD IN A STAGGERED PATTERN, BUT THE STRIPS TIGHTLY AGAINST EACH OTHER. DO NOT LEAVE SPACES AND DO NOT OVERLAP. A SHARPENED MASON'S TROWEL IS A HANDY TOOL FOR TUCKING DOWN THE ENDS AND TRIMMING PIECES.



DIRECTIONS FOR INITIAL MAINTENANCE

- Step 1. ROLL SOD IMMEDIATELY TO ACHIEVE FIRM CONTACT WITH THE SOIL
- Step 2. WATER TO A DEPTH OF 4" AS NEEDED. WATER WELL AS SOON AS THE SOD IS LAID.
- Step 3. MOW WHEN THE SOD IS ESTABLISHED -- IN 2-3 WEEKS. SET THE MOWER HIGH (2"-3").

APPEARANCE OF GOOD SOD

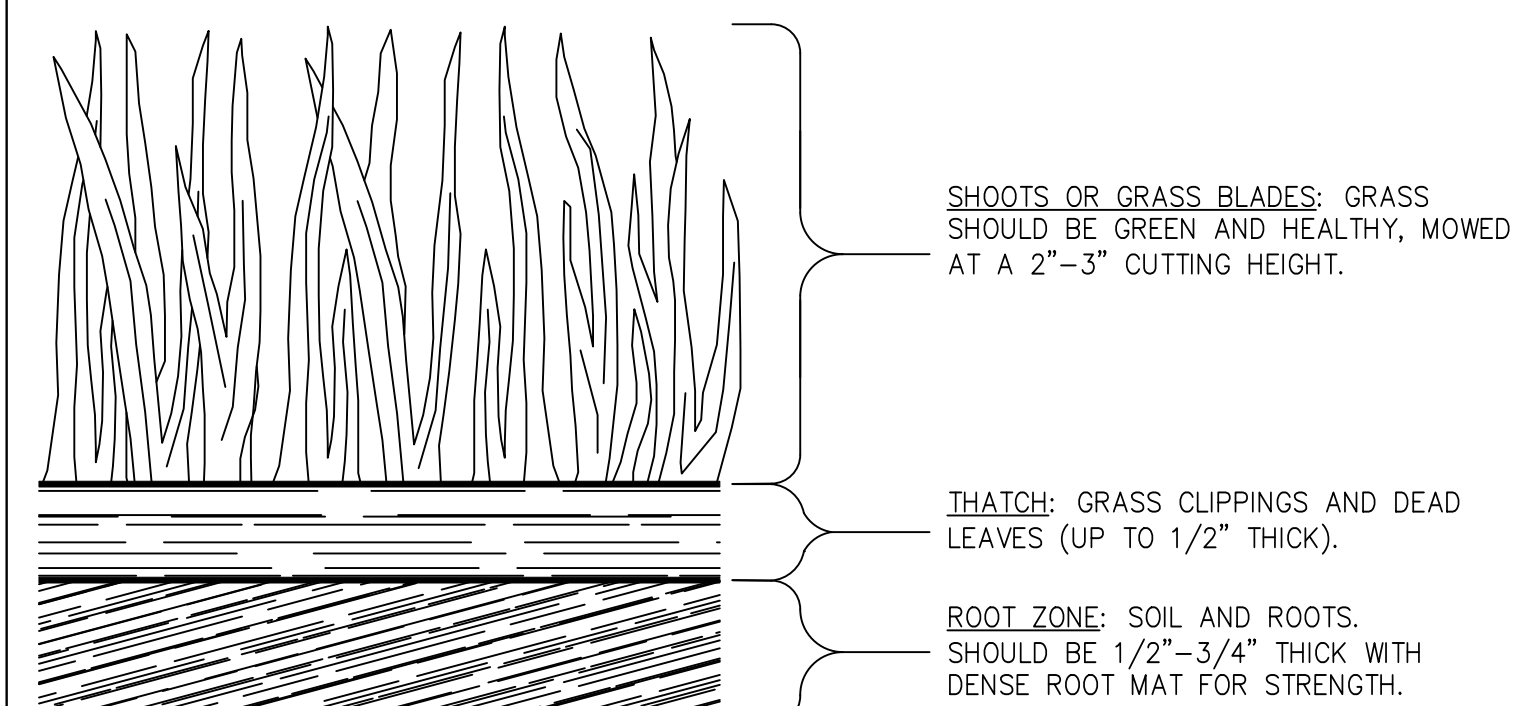

RAE

RICHARDS & ASSOCIATES ENGINEERING, INC.
CIVIL ENGINEERING + LAND PLANNING
P.O. BOX 220, CHATSWORTH, GA 30705
(706) 616-5906

© RICHARDS & ASSOC. ENGINEERING, INC.



Northwest Georgia Regional Library System
Dalton-Whitfield • Calhoun-Gordon • Chatsworth-Murray

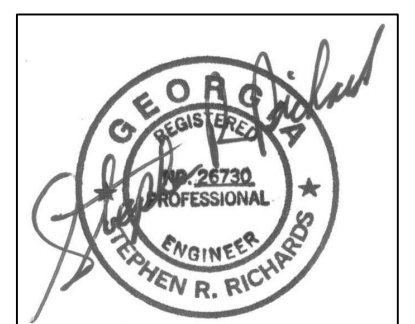
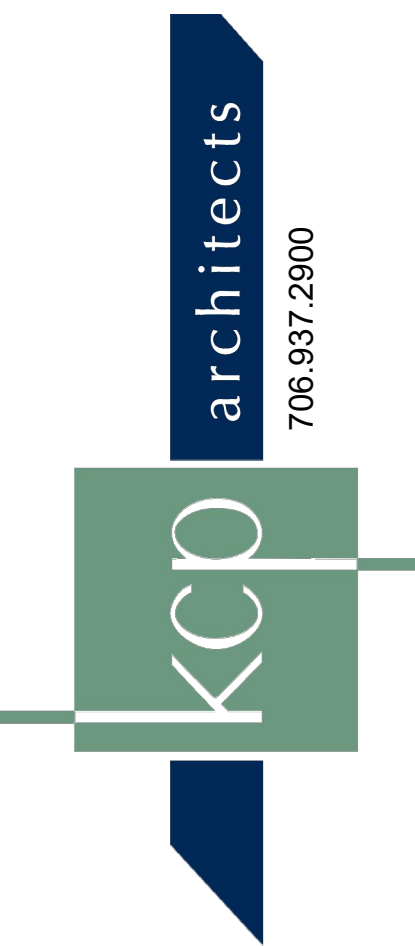

GA PROFESSIONAL ENGINEER NO. 26730
LEVEL II CERTIFIED DESIGN
PROFESSIONAL NO. 8688

PHASE #3
DALTON WHITFIELD COUNTY PUBLIC LIBRARY
READING PAVILION
310 CAPPES STREET. DALTON, GA

JOB NO. RAE 24-018
DATE 10/20/25
DRAWN BY SRR
REVISIONS

DRAWING TITLE
SOIL EROSION
SEDIMENTATION
AND POLLUTION
CONTROL
DETAILS

SHEET NO.

C5

Ds1 DISTURBED AREA STABILIZATION (WITH MULCHING ONLY) – 4 INCH MINIMUM COVERAGE

Ds2 PLANTS, PLANTING RATES, AND PLANTING DATES FOR TEMPORARY COVER OR COMPANION CROPS

Species	Broadcast Rates 2/ - PLS 3/ Per Acre	Resource Area	Planting Dates by Resource Areas												Remarks
			Planting Dates												
(Solid lines indicate optimum dates, dotted lines indicate permissible but marginal dates)															
			J	F	M	A	M	J	J	A	S	O	N	D	
MILLET, PEARL (Pennisetum glaucum) alone	50 lbs. 1.1 lb	M-L													88,000 seed per pound. Quick dense cover. May reach 3 feet in height. Not recommended for mixtures.
OATS (Avena sativa) alone	4 bu. (128 lbs.) 2.9 lb	M-L													13,000 seed per pound. Use on productive soils. Not as winterhardy as rye or barley.
OATS in mixtures	1 bu. (32 lbs.) 0.7 lb	M-L													
RYE (Secale cereale) alone	3 bu. (84 lbs.) 3.9 lb	M-L													18,000 seed per pound. Quick cover. Drought tolerant and winterhardy.
RYE in mixtures	1 1/2 bu. (36 lbs.) 0.6 lb	M-L													
RYEGRASS, ANNUAL (Lolium temulentum) alone	40 lbs. 0.9 lb	M-L													227,000 seed per pound. Dense cover. Very competitive in mixtures.
RYEGRASS in mixtures	10 lbs. 0.2 lb	M-L													
SUDANGRASS (Sorghum sudanese) alone	60 lbs. 1.4 lb	M-L													55,000 seed per pound. Good on droughty sites. Not recommended for mixtures.

TP

NOTES:

1. STOCKPILED TOPSOIL WILL BE COVERED WITH PLASTIC OR STRAW.
2. DEPENDING ON LOCATION, SILT FENCE MAY BE REQUIRED ON DOWNSTREAM SIDE OF STOCKPILE AREA.

VEGETATIVE PLAN FOR AREAS DISTURBED DURING CONSTRUCTION

All bare areas resulting from construction operations will be established to perennial vegetation as soon as possible after final grading is complete.

A. Initial Treatment

1. **Seedbed Preparation:** Prepare seedbed to depth of at least 4 inches on all areas where a good seedbed is not present. Remove rocks, roots, and other objects that will interfere with vegetation establishment or maintenance operations. No seedbed preparation is needed where hydroseeded. Lime must be included in initial seedbed preparation minimum coverage of 2 tons per acre.
2. **Fertilizer:** Apply 1500 pounds of 6-12-12 analysis fertilizer (or equivalent) per acre. Spread lime and fertilizer uniformly over all areas immediately before final land preparation and mix thoroughly with the soil. Apply topdressing of 50 pounds per acre of ammonium nitrate (or equivalent) when plants are 2 to 4 inches tall.
3. **Seeding:** All areas will be seeded with TALL FESCUE at a rate of 50 lbs. per acre or appropriate seasonal grass (SEE SEEDING SCHEDULE). Seed will be distributed uniformly over the area and covered to a depth of about 2 inches. If the area is to be sprigged, plant only freshly dug sprigs and keep them cool and moist until planted. Firm seeded or sodded areas with cultipacker or roller immediately following planting.
4. **Mulching:** Pond spillways and all seeded areas with slopes greater than 3 percent will be mulched immediately after seeding by spreading uniformly dry straw or hay, free from competing weeds, at the rate of about 2 tons per acre or to cover approximately 75 percent of the ground surface. When feasible, anchor mulch with a packer or disk harrow with the blades set straight or with emulsified asphalt (grade AES or SSI) at a rate of 100 gallons emulsion mixed with 100 gallons water for each ton of mulch.

B. Management

Second year application of 800 pounds of 6-12-12 analysis fertilizer per acre and topdress with 20 pounds of ammonium nitrate per acre. Apply agricultural limestone at the rate of 2 tons per acre every 4 to 6 years. The area may be mowed at proper season to control vegetation.

C. Other Requirements or Exceptions

Where liquid plastic materials are used with the hydroseeding operation, no hay mulch is required. When the season for seeding perennial seed has expired, a temporary cover of wheat or rye may be established. As soon as it is practical, perennial seed shall be sown in areas where a temporary cover has been sown.

Ds3 CRITICAL AREA VEGETATIVE PLAN Ds3

GENERAL: This vegetative plan will be carried out on road cut and fill slopes, shoulders, and other critical areas created by construction and land disturbance activities. Seeding will be done as soon as construction in an area is completed. Plantings will be made to control erosion, to reduce damages from sediment and runoff to downstream areas, and to improve the safety and beauty of the development area.

SOIL CONDITIONS: Due to grading and construction, the areas to be treated are mainly subsoil and substrate. Fertility is low and the physical characteristics of the exposed material are unfavorable to all but the most hardy plants.

TREATMENT SPECIFICATIONS

A. Hydroseeding: When hydraulic seeding and fertilizing equipment is used, no grading and shaping or seedbed preparation will be required. The fertilizer, seed and wood cellulose fiber mulch will be mixed with water and applied in a slurry. All slurry ingredients must be combined to form a homogeneous mixture, and spread uniformly over the area, leaving about 25% of the ground surface exposed.

B. Hand seeding: Grade, shape and smooth where needed to provide for safe equipment operation at seeding time and for maintenance purposes. The time and fertilizer in dry form will be spread uniformly over the area immediately before seedbed preparation. A seedbed will be done with cultipacker-seeder, drill, rotary seeder or other mechanical or hand seeder. Seed will be distributed uniformly over a freshly prepared seedbed and covered lightly. Within 24 hours after seeding, straw or hay mulch will be spread uniformly over the area, leaving about 25% of the ground surface exposed. Mulch will be spread with blower-type mulch equipment or by hand and anchored immediately after it is spread. A disk harrow with the disk set straight or a special packer disk may be used to press the mulch into the soil.

PREPARATION APPLICATION RATES

Agricultural limestone: 4000 lbs/acre Fertilizer 5-10-15: 1500 lbs/acre
 Mulch, straw or hay: 5000 lbs/acre Fiber mulch: 1000 lbs/acre **
 ** required only on hydroseeding operations

TOPDRESSING: To be applied when plants are 2-4 inches. Fertilize 300 lbs/acre

SECOND YEAR FERTILIZER

0-20-20 or equivalent: 500 lbs/acre (hydroseeding) or 5-10-15 800 lbs/acre

SEED SPECIES OPTIONS AND PLANTING DATES

Bermuda: 10 lbs/acre : 3/1 to 6/15 Lovegrass: 4 lbs/acre : 3/1 to 6/15
 Sericea lespedeza: 60 lbs/acre 3/1 to 6/15

Ds3 PLANTS, PLANTING RATES, AND PLANTING DATES FOR PERMANENT COVER

Species	Broadcast Rates 1/ - PLS 2/ Per Acre	Resource Area 3/	Planting Dates by Resource Areas												Remarks
			Planting Dates												
(Solid lines indicate optimum dates, dotted lines indicate permissible but marginal dates)															
			J	F	M	A	M	J	J	A	S	O	N	D	
BERMUDA SPRIGS (Cynodon dactylon) Coastal, Common, Midland, or Tilt 44	40 cu. ft. 0.9 cu. ft. or spd plugs 3' x 3'	M-L													A cubic foot contains approximately 650 sprigs. A bushel contains 1.25 cubic feet or approximately 800 sprigs.
Coastal, Common, or Tilt 44 Tilt 78															
BAHIA, WILMINGTON (Paspalum notatum) alone or with temporary cover with other perennids	60 lbs. 1.4 lb 30 lbs. 0.7 lb	M-L													166,000 seed per pound. Low growing. Soil forming. Slow to establish. Plant with a companion crop. Will spread into bermuda pastures and lawns. Mix with Sericea lespedeza or weeping lovegrass.
CROWNVEATCH (Coronilla varia) with winter annuals or cool seasons grasses	15 lbs. 0.3 lb	M-L													100,000 seeds per pound. Dense growth. Drought tolerant and fire resistant. Attractive rose, pink, and white blossoms spring to late fall. Mix with 30 pounds of Tall fescue or 15 pounds of rye. Inoculate seed with M inoculant. Use from North Atlanta and Northside.
FESCUE, TALL (Festuca arundinacea) alone with other perennids	50lbs 1.1 lb. 30lbs 0.7 lb.	M-L													227,000 seeds per pound. Use alone only on better sites. Not for droughty soils. Mix with perennial lespedezas or Crownveatch. Apply topdressing in spring following fall plantings. Not for heavy use areas or athletic fields.
REED CANARY GRASS (Phalaris arundinacea) alone with other perennids	50 cu. ft. 1.1 cu. ft. 30 cu. ft. 0.7 cu. ft.	M-L													Grows similar to Tall fescue.

- 1/ Reduce seeding rates by 50% when drilled.
- 2/ PLS is an abbreviation for Pure Live Seed.
- 3/ M-L represents to Mountain; Blue Ridge; and Ridges and Valleys MLRAs.

SEEDING NOTE: IF PERMANENT VEGETATION IS REQUIRED BEFORE SEPTEMBER 15, USE THE APPROPRIATE SEED AND FERTILIZER FROM THE CHARTS.

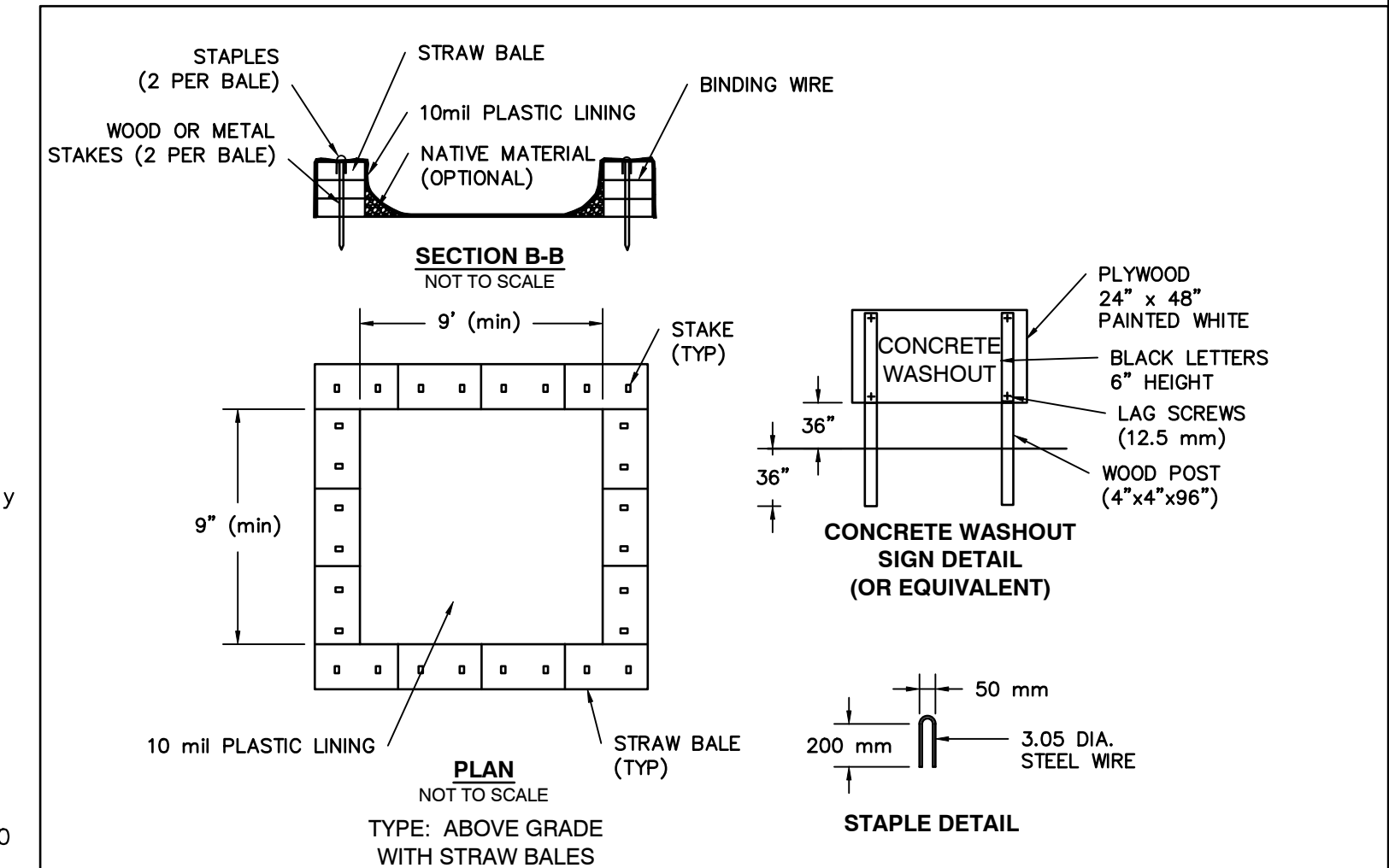

NOTES:

1. ACTUAL LAYOUT DETERMINED IN THE FIELD.
2. THE CONCRETE WASHOUT SIGN SHALL BE INSTALLED WITHIN 10 m OF THE TEMPORARY CONCRETE WASHOUT FACILITY.

NOTES:

1. Temporary concrete washout facilities shall be located a minimum of 50 ft from storm drain inlets, open drainage facilities, and watercourses, unless determined infeasible. Each facility shall be located away from construction traffic or access areas to prevent disturbance or tracking.
2. A sign shall be installed adjacent to each washout facility to inform concrete equipment operators to utilize the proper facilities.
3. Temporary concrete washout facilities shall be constructed and maintained in sufficient quantity and size to contain all liquid and concrete waste generated by washout operations.
4. Temporary washout facilities shall have a temporary pit or bermed areas of sufficient volume to completely contain all liquid and waste concrete materials generated during washout procedures.
5. Perform washout of concrete mixer trucks in designated areas only.
6. Wash concrete only from mixer truck shoots/chutes into concrete wash outapproved concrete washout facility. Washout may be collected in an impermeable bag for disposal.
7. Pump excess concrete in concrete pump bin back into concrete mixer truck.
8. Concrete washout from concrete pumper bins can be washed into concrete pumper trucks and discharged into designated washout area or properly disposed offsite.
9. Transit trucks are not to be washed at concrete washout.
10. Once concrete wastes are washed into the designated area and allowed to harden, the concrete shall be broken up, removed, and disposed of per state and local regulations.
11. On site concrete waste storage and disposal procedures shall be monitored at least weekly.
12. When temporary concrete washout facilities are no longer required for the work, the hardened concrete shall be removed and disposed of in conformance with state and local regulations.
13. Holes, depressions or other ground disturbance caused by the removal of the temporary concrete washout facilities shall be backfilled and repaired.

TEMPORARY ON-SITE CONCRETE TRUCK WASH

TABLE 3. FERTILIZER RATES

PLANTING OPTIONS	YEAR	ANALYSIS	# PER ACRE	# PER 1000 SQ. FT.	# PER ACRE	# PER 1000 SQ. FT.
TALL FESCUE	AT PLANTING	6-12-12	1500	35	50-100	1.2-2.3
COMMON BERMUDA (HULLLED) RYE GRASS	YEAR TWO	6-12-12	1000	25	50-100	1.2-2.3
TALL FESCUE	AT PLANTING	6-12-12	1500	35	50-100	1.2-2.3
APPALOW LESPEDEZA (UNSCARIFIED) RYE GRASS	YEAR TWO	0-10-10	1000	25	50-100	1.2-2.3
TALL FESCUE	AT PLANTING	6-12-12	1500	35	50-100	1.2-2.3
RYE GRASS	YEAR TWO	10-10-10	1000	25	50-100	1.2-2.3
CROWNVEATCH	AT PLANTING	6-12-12	1500	35	0-50	0-1.2
RYE GRASS	YEAR TWO	0-10-10	1000	25	50-100	1.2-2.3
WEeping LOVEGRASS	AT PLANTING	6-12-12	1500	35	50-100	1.2-2.3
APPALOW LESPEDEZA (SCARIFIED) BROWNTOP MILLET	YEAR TWO	6-12-12	1000	25	50-100	1.2-2.3
SUNFLOWER "ATED MAXIMILIANT" WEeping LOVEGRASS	AT PLANTING	6-12-12	1500	35	50-100	1.2-2.3
YEAR TWO	6-12-12	1000	25	50-100	1.2-2.3	
COMMON BERMUDA (HULLLED) BROWNTOP MILLET	AT PLANTING	6-12-12	1500	35	50-100	1.2-2.3
YEAR TWO	6-12-12	1000	25	50-100	1.2-2.3	
WEeping LOVEGRASS	AT PLANTING	6-12-12	1500	35	50-100	1.2-2.3
YEAR TWO	6-12-12	1000	25	50-100	1.2-2.3	
TALL FESCUE	AT PLANTING	6-12-12	1500	35	50-100	1.2-2.3
YEAR TWO	10-10-10	1000	25	50-100	1.2-2.3	

Du DUST CONTROL

NOTES:

1. The generation of dust during grading operations will be controlled by the use of temporary vegetation and mulching in disturbed areas.
2. In an emergency situation, the site should be sprinkled with water until the surface is wet. This process should be repeated as necessary.
3. All disturbed areas must be grassed with permanent vegetation within 14 days of achieving finished grade.

STONE CHECK DAM

SPACING BETWEEN CHECK DAMS

Cd-S

A = THE TOE OF THE UPSTREAM CHECK DAM.
 B = TOP OF THE DOWNSTREAM CHECK DAM.
 L = THE DISTANCE SUCH THAT POINTS A AND B ARE OF EQUAL ELEVATION.

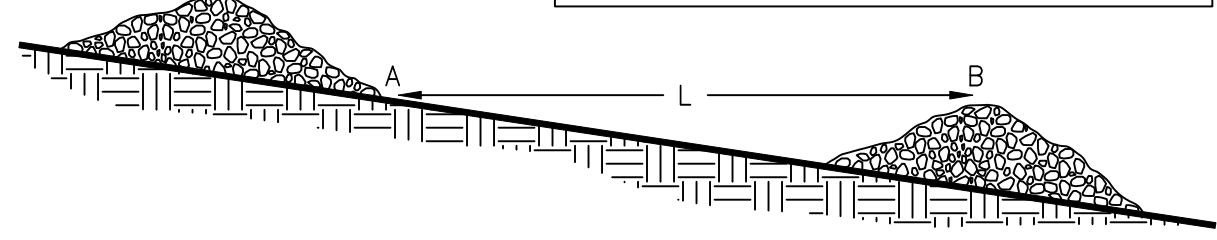

STONE CHECK DAM

CROSS SECTION

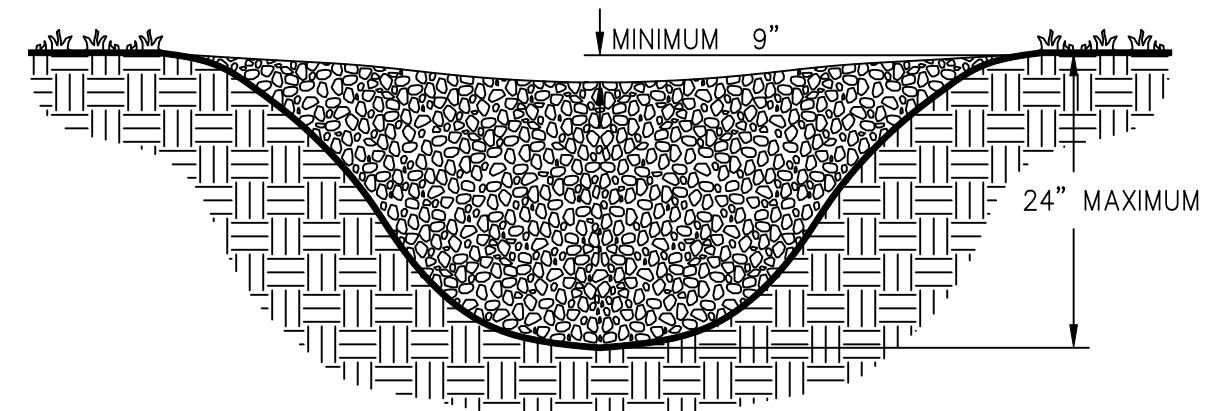

PROFILE VIEW

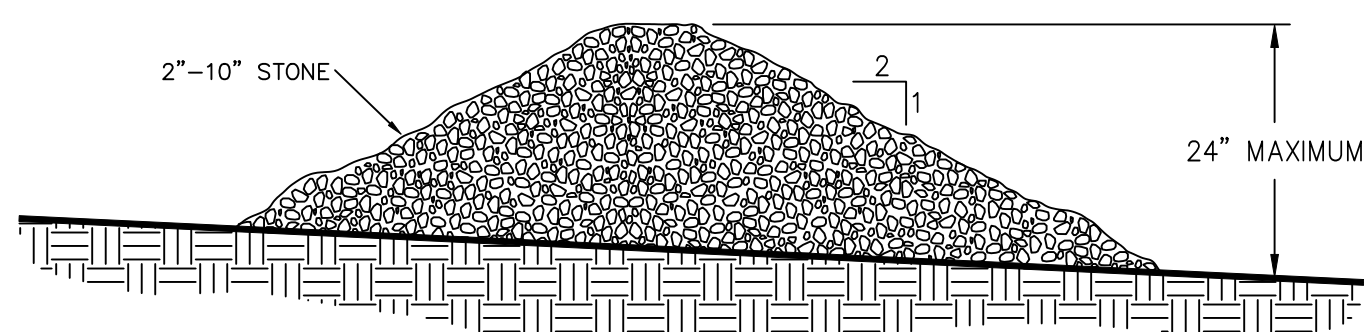

NOTES:

1. CHECK DAMS ARE TO BE USED ONLY IN SMALL OPEN CHANNELS (THEY ARE NOT TO BE USED IN LIVE STREAMS).
2. THE DRAINAGE AREA FOR STONE CHECK DAMS SHALL NOT EXCEED TWO ACRES.
3. THE CENTER OF THE CHECK DAM MUST BE AT LEAST 9 INCHES LOWER THAN THE OUTER EDGES.
4. THE DAM HEIGHT SHOULD BE A MAXIMUM OF 2 FEET FROM CENTER TO RIM EDGE.
5. THE SIDE SLOPES OF THE CHECK DAM SHALL NOT EXCEED A 2:1 SLOPE.
6. GEOTEXTILE SHALL BE USED TO PREVENT THE MITIGATION OF SUBGRADE SOIL PARTICLES INTO THE STONES (REFER TO AASHTO M288-96, SECTION 7.3, TABLE 3).

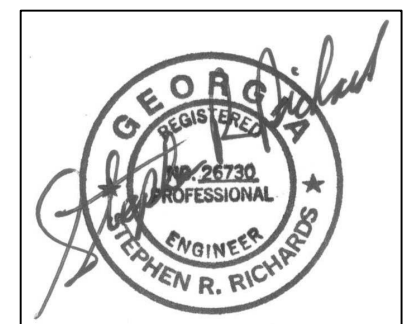
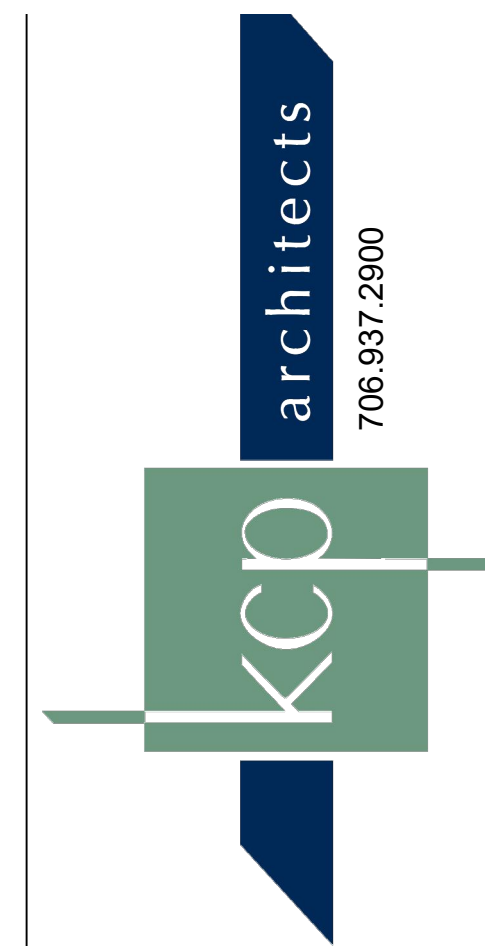

GA PROFESSIONAL ENGINEER NO. 26730
 LEVEL II CERTIFIED DESIGN
 PROFESSIONAL NO. 8688

PHASE #3
 DALTON WHITFIELD COUNTY PUBLIC LIBRARY
READING PAVILION
 310 CAPPES STREET.
 DALTON, GA

JOB NO. RAE 24-018
 DATE 10/20/25
 DRAWN BY SRR
 REVISIONS

DRAWING TITLE
**SOIL EROSION
 SEDIMENTATION
 AND POLLUTION
 CONTROL
 DETAILS**

SHEET NO.

C6



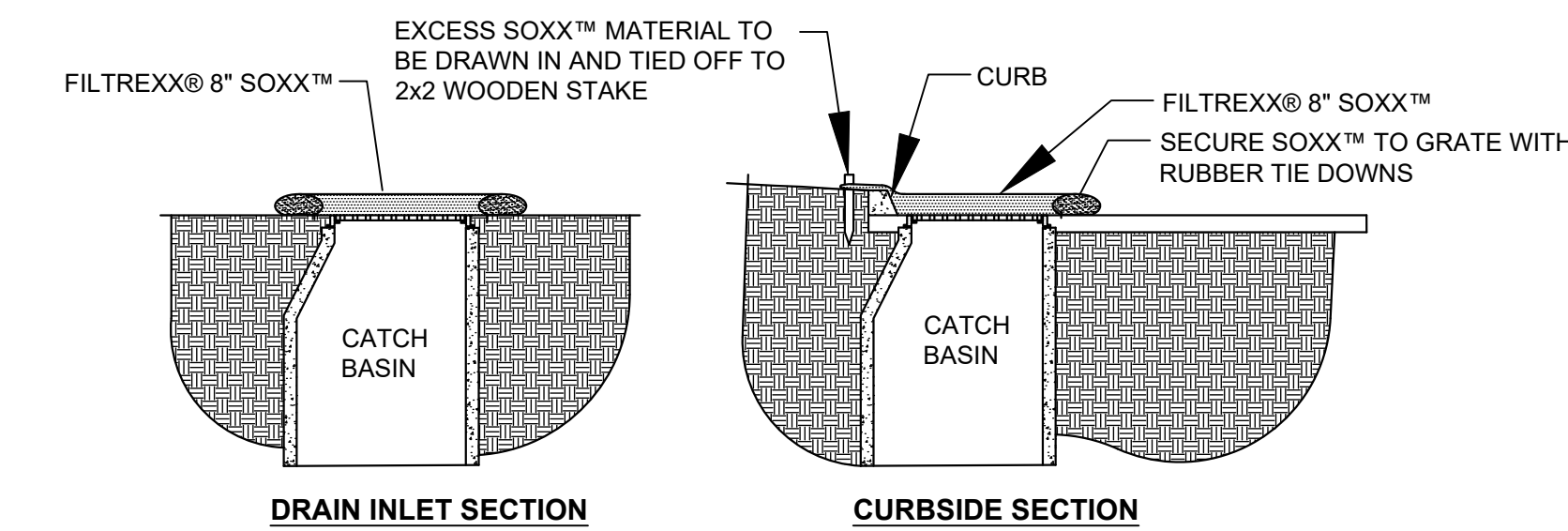
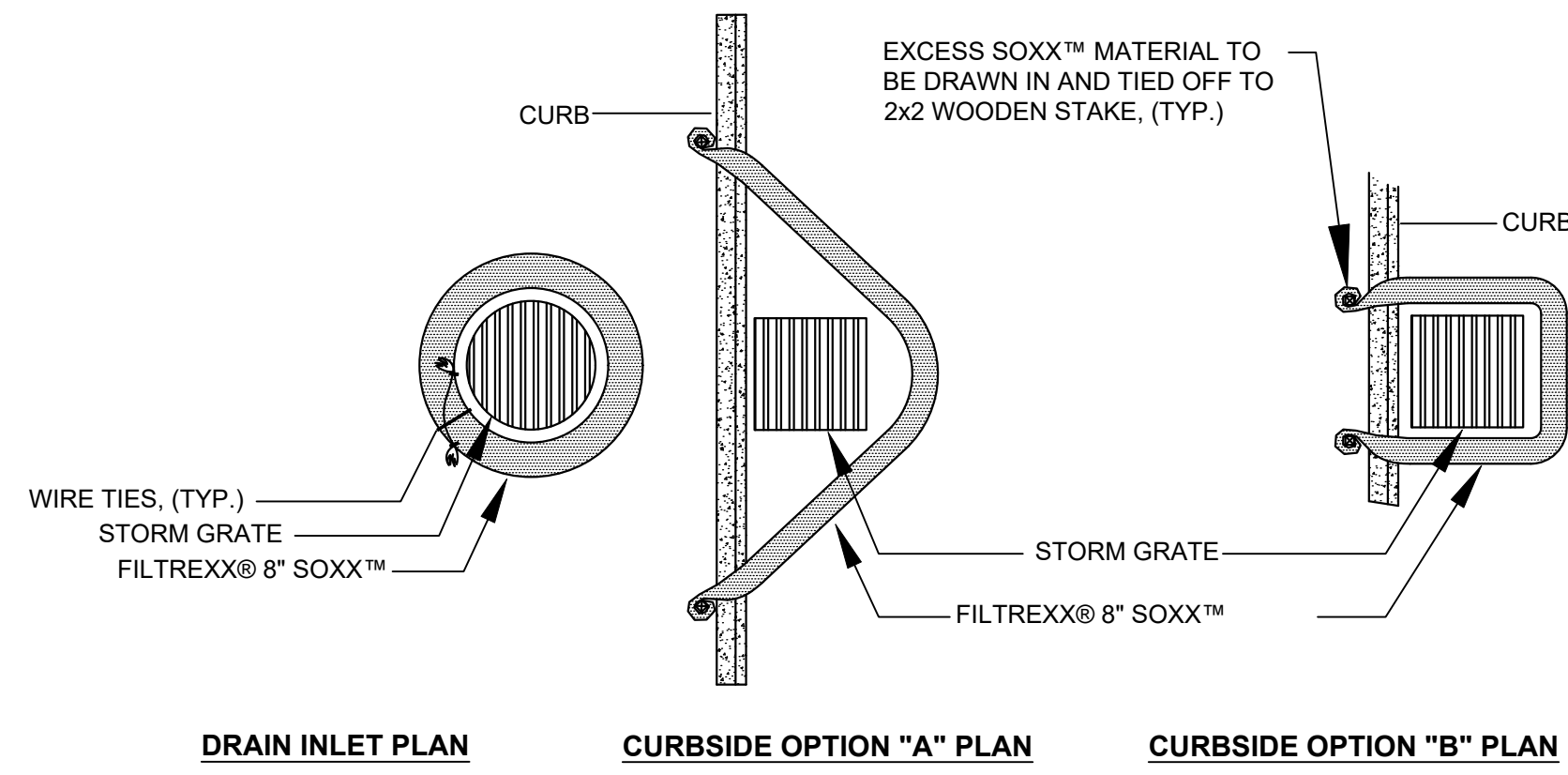

Sd2-P

- NOTES:
1. ALL MATERIAL TO MEET FILTREXX® SPECIFICATIONS.
 2. FILTER MEDIA™ FILL TO MEET APPLICATION REQUIREMENTS.
 3. COMPOST MATERIAL TO BE DISPERSED ON SITE, AS DETERMINED BY ENGINEER.

FILTREXX® INLET PROTECTION NTS

GEOTEXTILE FABRICS

STONE/SOIL INTERFACE
CONTECH FILTER FABRIC
(OR APPROVED EQUAL
PER GDOT QUALIFIED PRODUCT LIST #28)

PROPEX GEOTEX 102F FOR WOVEN FABRIC
PROPEX GEOTEX 351 FOR NON-WOVEN FABRIC

TURF REINFORCEMENT MAT

PROPEX TRM
(OR APPROVED EQUAL
PER GDOT QUALIFIED PRODUCT LIST #49)

PROPEX LANDLOK 450 FOR DITCH FLOWS UP TO 18fps AND SLOPES 3:1 AND FLATTER

PROPEX PYRAMAT 75 FOR DITCH FLOWS UP TO 25fps AND SLOPES GREATER THAN 3:1

FABRIC AND SUPPORTING FRAME FOR INLET PROTECTION

STEEL FRAME AND SILT FENCE INSTALLATION

Sd2-F

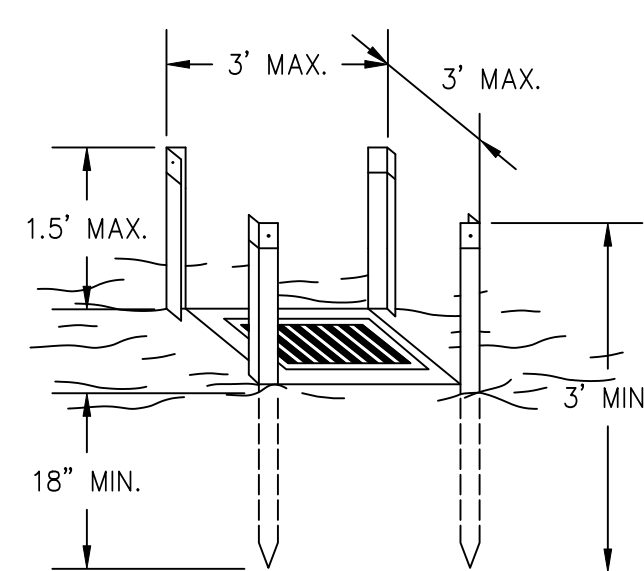

- NOTES:
1. DESIGN IS FOR SLOPES NO GREATER THAN 5% (NOT DESIGNED FOR CONCENTRATED FLOWS).
 2. THE STEEL POSTS SUPPORTING THE SILT FENCE MATERIAL SHOULD BE SPACED EVENLY AROUND THE PERIMETER OF THE INLET (MAXIMUM OF 3' APART).
 3. THE STEEL POSTS SHOULD BE SECURELY DRIVEN AT LEAST 18" DEEP.
 4. THE FABRIC SHOULD BE ENTRENCHED AT LEAST 12" AND THEN BACKFILLED WITH CRUSHED STONE OR COMPACTED SOIL.

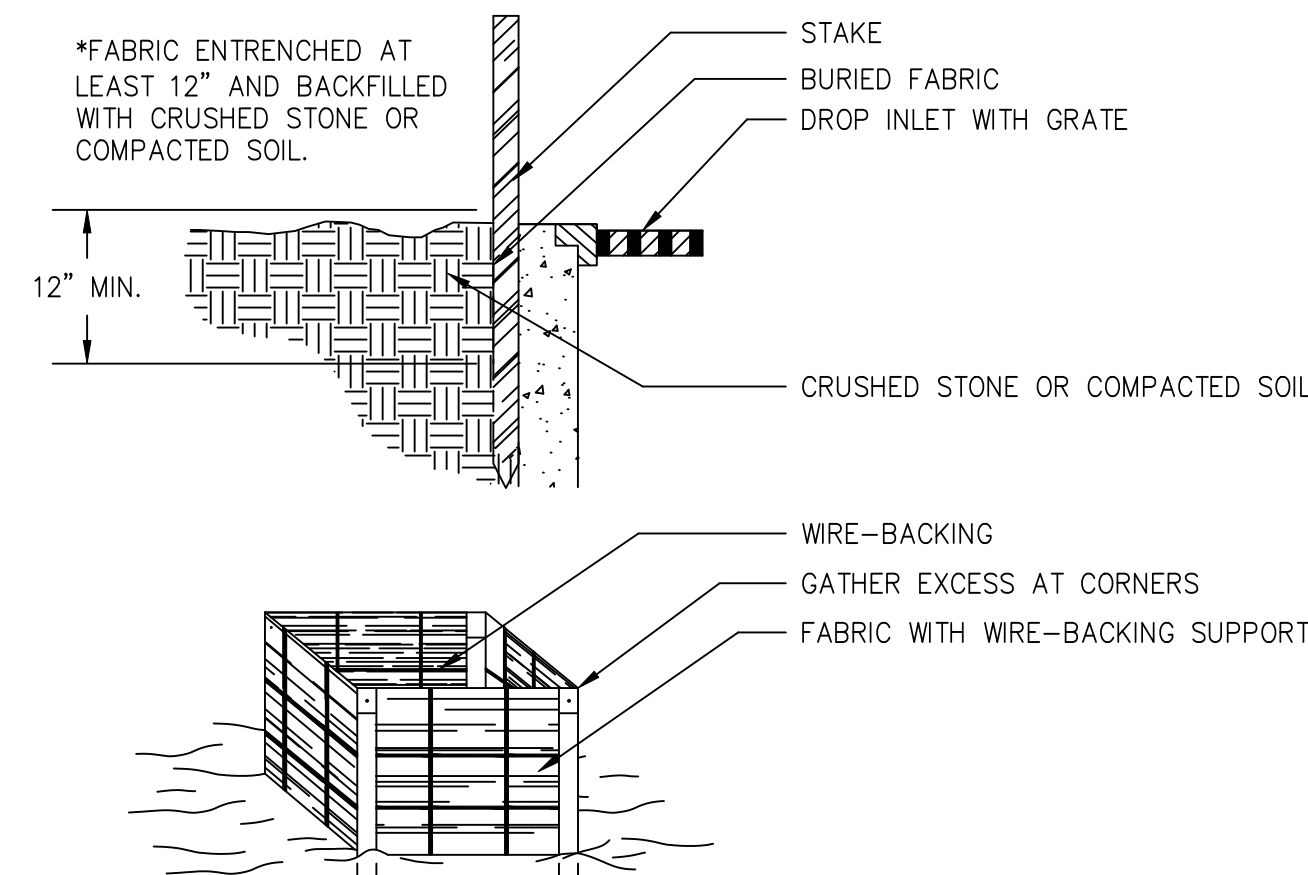

WATTLE SEDIMENT RETENTION FIBER ROLL (SRFR) INSTALLATION GUIDE

Base Soil Slope Installation
Prepare an even surface, free of debris and rocks. Seal and fertilize slope. Excavate a trench, placing the excavated soil on the upslope side of the trench per the Spacing on Slopes Detail. Space the SRFRs along the slope per the Spacing on Slopes Detail. Match the anchor trench with the profile of the SRFR to ensure a snug fit. Place the SRFR in the trench and install the 1"x1" wooden stakes through the center of the SRFR, leaving no more than 2" of the stake exposed and perpendicular to the horizontal ground slope, 4' on center. Create a soil wedge with the excavated soil and compact well on the upslope side of the SRFR. Secure the ends of the SRFRs per the SRFR Connection/Overlapping Detail.

RECP/HECF Protected Slope Installation
Space the SRFRs down the slope on the top of the RECP or HECF per the Spacing on Slopes Detail. Install the SRFRs along the contour with a slight downward angle at the end of each row to prevent ponding at the midsection. Turn each end of the row upslope on a 45 degree angle. Install the 1"x1" wooden stakes on the downslope side of the SRFR and through the RECP or HECF, by penetrating only the netting of the SRFR and not the SRFR matrix. Secure the ends of the SRFRs by tightly coating the ends and the SRFRs and driving a 1"x1" wooden stake through the center of the adjoining SRFR at an angle towards the first installed SRFR. Continue to install the wooden stakes on the downslope side of the second SRFR.

Perimeter Control and Minor Slopes (6:1)
Excavate a 3" deep trench to match the profile of the SRFR at the perimeter of the project and install per the Perimeter Control Detail. For installation along sidewalks and behind street curbs, a 3" trench must be excavated, but staking might not be required.

Channel Check Dam Installation
For bare soil channels, excavate a 3" anchor trench across the width of the channel and perpendicular to the flow path. The anchor trench must be extended at least 1' above the wetted perimeter of both side slopes of the channel. Match the anchor trench with the profile of the SRFR to ensure a snug fit. For bare soil channels and RECP lined channels, install 36" 2"x2" wooden stakes, starting at the centerline of the channel and then extending outward every two feet, on the downstream side of the SRFR to the top and bottom of the stakes with a coil twine, or similar material.

Low Flow Inlet Protection
Excavate a 3" deep trench, 1'-12" upslope of the inlet. Match the trench to the profile of the SRFR to ensure a snug fit. Place the excavated soil upslope of the trench. Place the SRFR in the trench and install the 1"x1" wooden stakes every 2' through the center of the SRFR, leaving no more than 2" of the stake exposed. Create a soil wedge with the excavated soil and compact well on the upslope side of the SRFR. Ensure the heel with the SRFR and overlap the ends a minimum of 12", making sure to leave no gaps, where water can run directly into the inlet.

SRFR DIAMETER	WOODEN STAKE LENGTH
9" SRFR	24"
12" SRFR	24"
20" SRFR	36"

Carthage Mills
4243 Hunt Road
Cincinnati, OH 45242
800-543-4430
www.CarthageMills.com

SINCE 1958:
AMERICA'S FIRST
GEOSYNTHETICS
COMPANY

Sd1-NS SLOPER INTERRUPTER
FILTREXX IS AN APPROVED ALTERNATE



RICHARDS & ASSOCIATES ENGINEERING, INC.
CIVIL ENGINEERING + LAND PLANNING
P.O. BOX 220, CHATSWORTH, GA 30705
(706) 616-5906

© RICHARDS & ASSOC. ENGINEERING, INC.



Northwest Georgia Regional Library System
Dalton-Whitfield • Calhoun-Gordon • Chatsworth-Murray

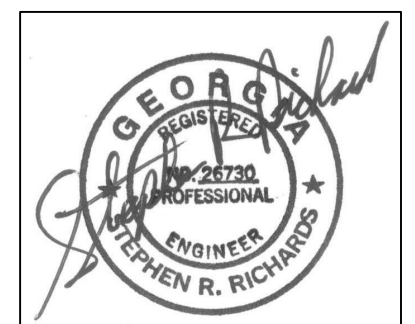
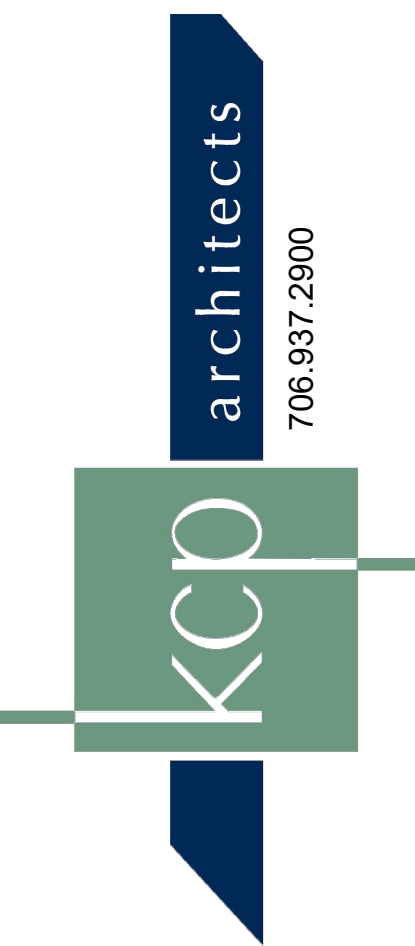

GA PROFESSIONAL ENGINEER NO. 26730
LEVEL II CERTIFIED DESIGN
PROFESSIONAL NO. 8668

PHASE #3
DALTON WHITFIELD COUNTY PUBLIC LIBRARY
READING PAVILION
310 CAPPES STREET. DALTON, GA

JOB NO. RAE 24-018
DATE 10/20/25
DRAWN BY SRR
REVISIONS

DRAWING TITLE
SOIL EROSION
SEDIMENTATION
AND POLLUTION
CONTROL
PLAN

SHEET NO.

C7



Northwest Georgia Regional Library System
Dalton-Whitfield • Calhoun-Gordon • Chatsworth-Murray

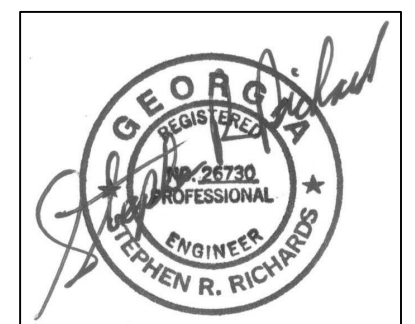
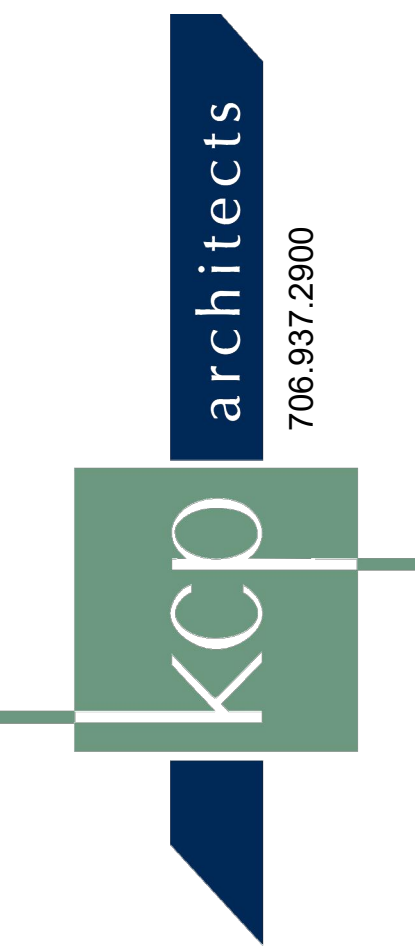

GA PROFESSIONAL ENGINEER NO. 26730
LEVEL II CERTIFIED DESIGN
PROFESSIONAL NO. 8688

PHASE #3
DALTON WHITFIELD COUNTY PUBLIC LIBRARY
READING PAVILION
310 CAPPES STREET. DALTON, GA

JOB NO. RAE 24-018
DATE 10/20/25
DRAWN BY SRR
REVISIONS

DRAWING TITLE
EXISTING
CONDITIONS
AND
DEMOLITION
PLAN

SHEET NO.

C8



RICHARDS & ASSOCIATES ENGINEERING, INC.
CIVIL ENGINEERING + LAND PLANNING
P.O. BOX 220, CHATSWORTH, GA 30705
(706) 616-5906

© RICHARDS & ASSOC. ENGINEERING, INC.

DEMOLITION NOTES

1. THE SITE IS OCCUPIED BY EXISTING BUILDINGS, STORM LINES, PAVEMENT, POWER POLES AND UTILITIES. IT IS THE CONTRACTOR'S RESPONSIBILITY TO CONTACT ALL UTILITY COMPANIES THAT MAY HAVE UTILITIES ON THE SITE TO GET A DETERMINATION IF ANY UTILITIES EXIST THAT WILL BE IMPACTED AND DETERMINE THE REQUIRED PROCEDURE FOR ABANDONMENT OF THE EXISTING UTILITIES.
2. EXISTING PAVEMENT, BUILDING SLABS AND FOOTINGS SHALL BE REMOVED FROM THE SITE AND DISPOSED IN A WASTE DISPOSAL AREA AS APPROVED BY LOCAL AND STATE ORDINANCE.
3. STORM SEWER AND SANITARY SEWER LINES IN ALL PROPOSED BUILDING AND PAVEMENT AREAS SHALL BE DEMOLISHED AND REMOVED FROM SITE.
4. UTILITY LINES SHALL BE DEMOLISHED AND REMOVED FROM THE SITE.
5. THE ENTIRE "BUILDING AREA" SHALL BE CLEANED OF ALL EXISTING PAVEMENT, BUILDING SLABS, FOOTINGS AND FOUNDATIONS, UTILITIES AND SEWERS. NO EXISTING FACILITIES SHALL BE LEFT UNDER BUILDING AREA.
6. ALL AREAS WHERE PAVEMENT, BUILDING SLABS, FOUNDATIONS, UTILITIES, CONDUITS, AND/OR UTILITY STRUCTURES HAVE BEEN REMOVED SHALL BE BACKFILLED WITH SELECT BACKFILL MATERIAL. ALL SELECT BACKFILL MATERIAL SHALL BE PLACED AND COMPACTED PER THE REQUIREMENTS OF THE SPECIFICATIONS AND THE ON-SITE GEOTECHNICAL ENGINEER.
7. EXISTING SEPTIC TANKS SHALL BE PUMPED BY A LICENSED CONTRACTOR. ALL SEPTIC TANKS AND DRAIN FIELD LINES SHALL BE REMOVED AND THE AREAS BACKFILLED WITH SELECT MATERIALS PER THE ON-SITE GEOTECHNICAL ENGINEER PER HEALTH DEPARTMENT AND STATE REGULATIONS.
8. EXISTING WELLS SHALL BE BACKFILLED PER GA ENVIRONMENTAL PROTECTION DIVISION REQUIREMENTS AND INSPECTED BY LOCAL COUNTY JURISDICTION ENVIRONMENTAL HEALTH.
9. ALL EXISTING FENCES LOCATED ON-SITE SHALL BE DEMOLISHED AND REMOVED.

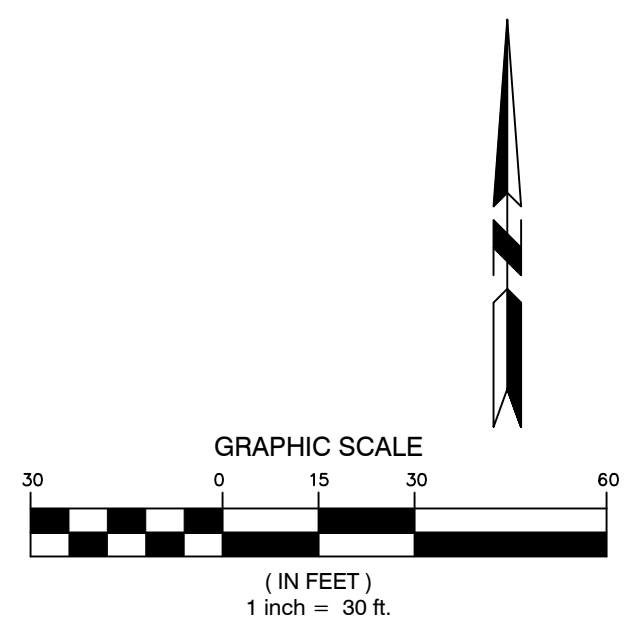
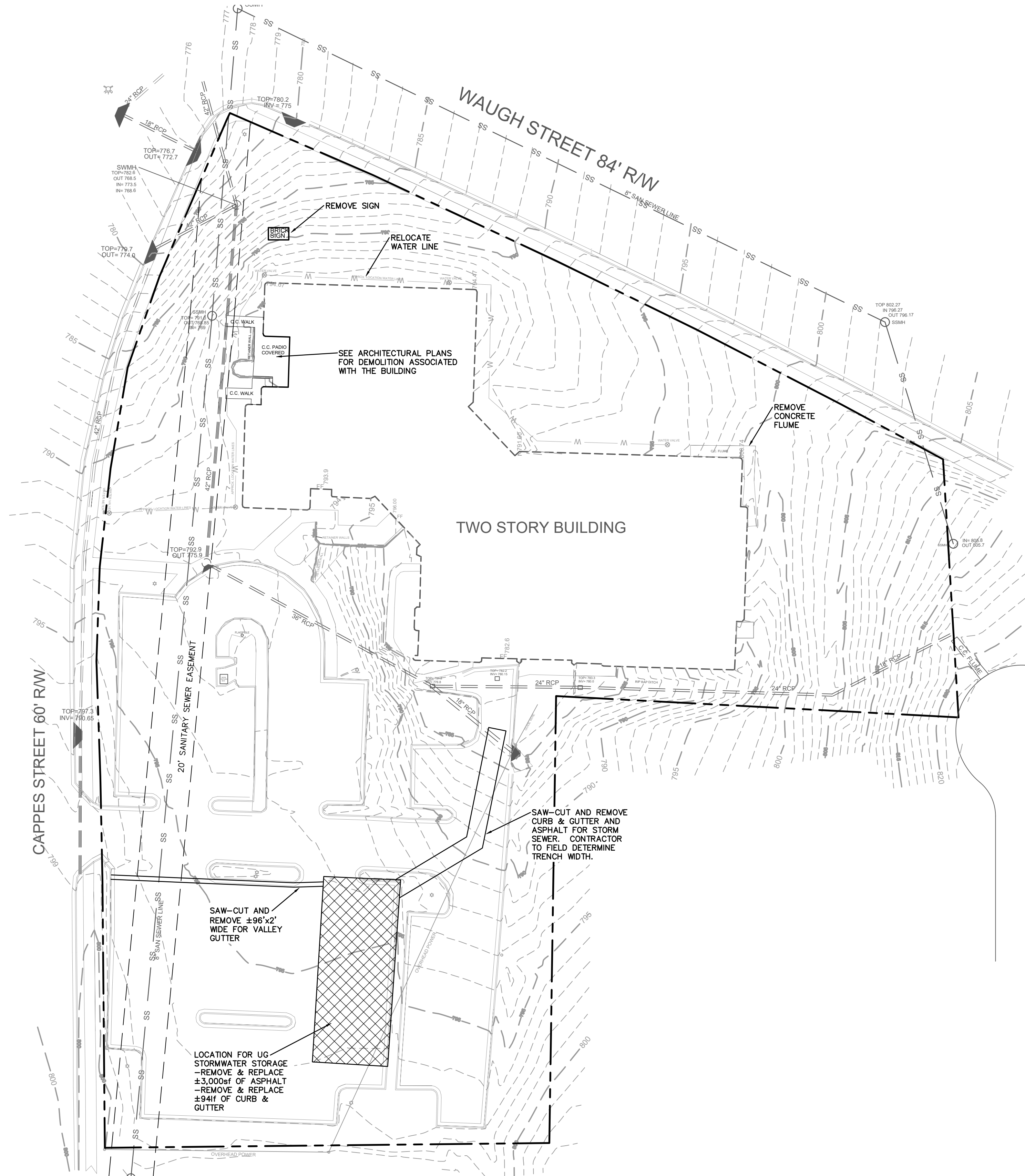



Northwest Georgia Regional Library System
Dalton-Whitfield • Calhoun-Gordon • Chatsworth-Murray

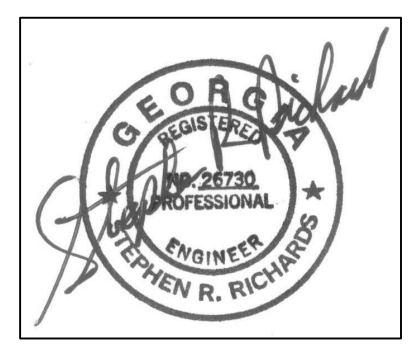
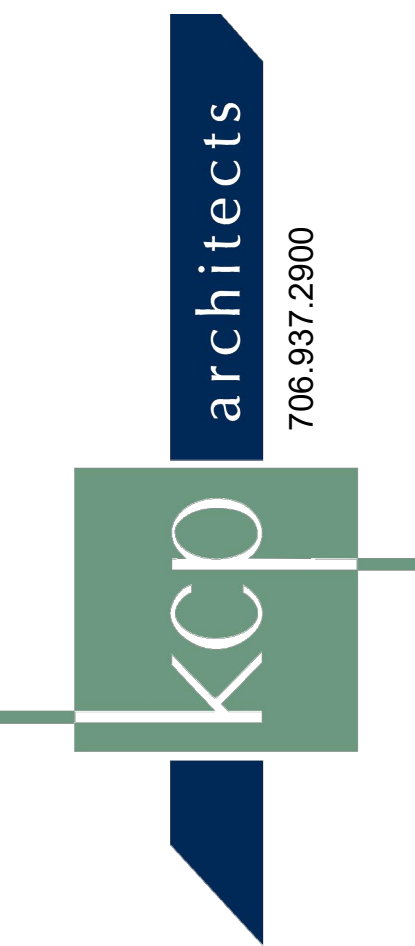

GA PROFESSIONAL ENGINEER NO. 26730
LEVEL II CERTIFIED DESIGN PROFESSIONAL NO. 8688

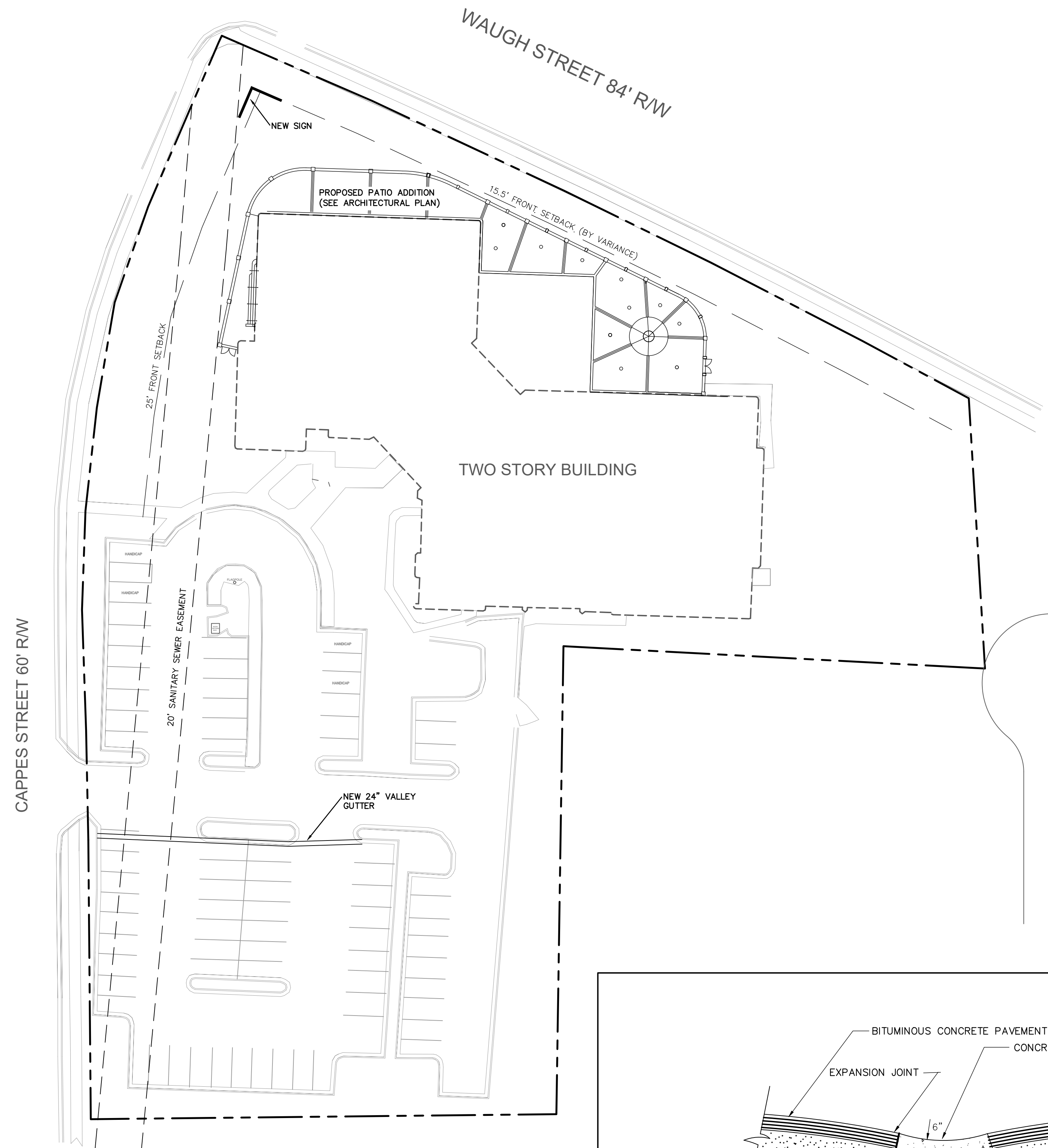
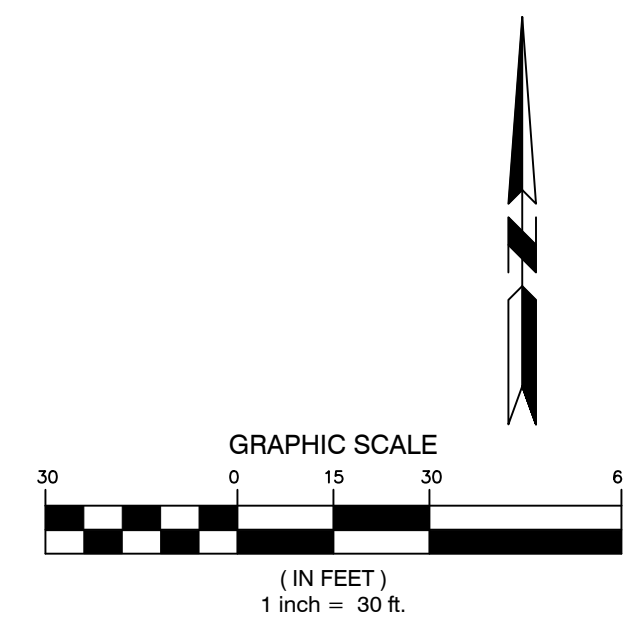

SITE NOTES

- 1. ALL WORK WILL COMPLY WITH APPLICABLE STATE, FEDERAL, AND LOCAL CODES, SPECIFICATIONS AND REQUIREMENTS. ALL NECESSARY LICENSES AND PERMITS SHALL BE OBTAINED BY THE CONTRACTOR AT HIS EXPENSE.
2. DEVIATIONS FROM THESE PLANS AND NOTES WITHOUT PRIOR CONSENT OF THE OWNER, HIS REPRESENTATIVE, OR THE ENGINEER MAY CAUSE THE WORK TO BE UNACCEPTABLE.
3. THIS SET OF DRAWINGS IS INTENDED TO COVER A COMPLETE PROJECT, READY TO USE. ALL ITEMS NECESSARY FOR A COMPLETE AND WORKABLE JOB SHALL BE FURNISHED AND INSTALLED. THIS WILL INCLUDE ALL STRIPING AND PARKING LOT SIGNAGE.
4. CONTRACTOR SHALL FURNISH AND MAINTAIN ANY AND ALL NECESSARY BARRICADES AROUND THE WORK FOR THE PROTECTION OF THE PUBLIC AND CONSTRUCTION EMPLOYEES AND PROVIDE PROTECTION AGAINST WATER DAMAGE AND SOIL EROSION.
5. ALL BUILDING DIMENSIONS SHALL BE CHECKED AND COORDINATED WITH THE ARCHITECTURAL PLANS.
6. FOR OTHER CONSTRUCTION DETAILS, SEE DETAIL SHEETS.
7. ALL SITE DIMENSIONS ARE TO THE FACE OF CURB OR EDGE OF PAVEMENT, EXCEPT WHERE NOTED.
8. ALL ON SITE CURB SHALL BE 24" CURB & GUTTER OR 18" VERTICAL CURB.
9. ALL WORK ON-SITE MUST CONFORM TO LOCAL COUNTY JURISDICTION STANDARDS.
10. SEE DETAILS FOR PAVING SECTIONS.
11. PAVEMENT MARKING, INCLUDING STANDARD HANDICAP SYMBOLS, PARKING STRIPING AND TRAFFIC ARROWS, SHALL BE PAINTED ON PAVEMENT AT LOCATIONS SHOWN. SEE PAVEMENT MARKING DETAIL.
12. SITE CONTRACTOR TO VERIFY EXISTING TOPOGRAPHIC AND UTILITY DATA PRIOR TO ANY CONSTRUCTION.
13. PROVIDE BOLLARDS AT LOCATIONS SHOWN, AND AROUND TRANSFORMERS, GAS METERS, AND OTHER UTILITIES IN VULNERABLE TRUCK AREAS.
14. WARRANTY: THIS SUBCONTRACTOR SHALL WARRANT ALL ASPHALT AGAINST ALL DEFECTS IN MATERIALS AND WORKMANSHIP FOR A PERIOD OF TWO(2) YEARS.
15. CONTRACTOR MUST OBTAIN ENCROACHMENT PERMIT FROM LOCAL COUNTY JURISDICTION PUBLIC WORKS PRIOR TO BEGINNING ANY WORK IN THE RIGHT-OF-WAY.

SITE LEGEND table with symbols for property lines, fencing, traffic flow, striping, parking bays, paving types, and screened features.

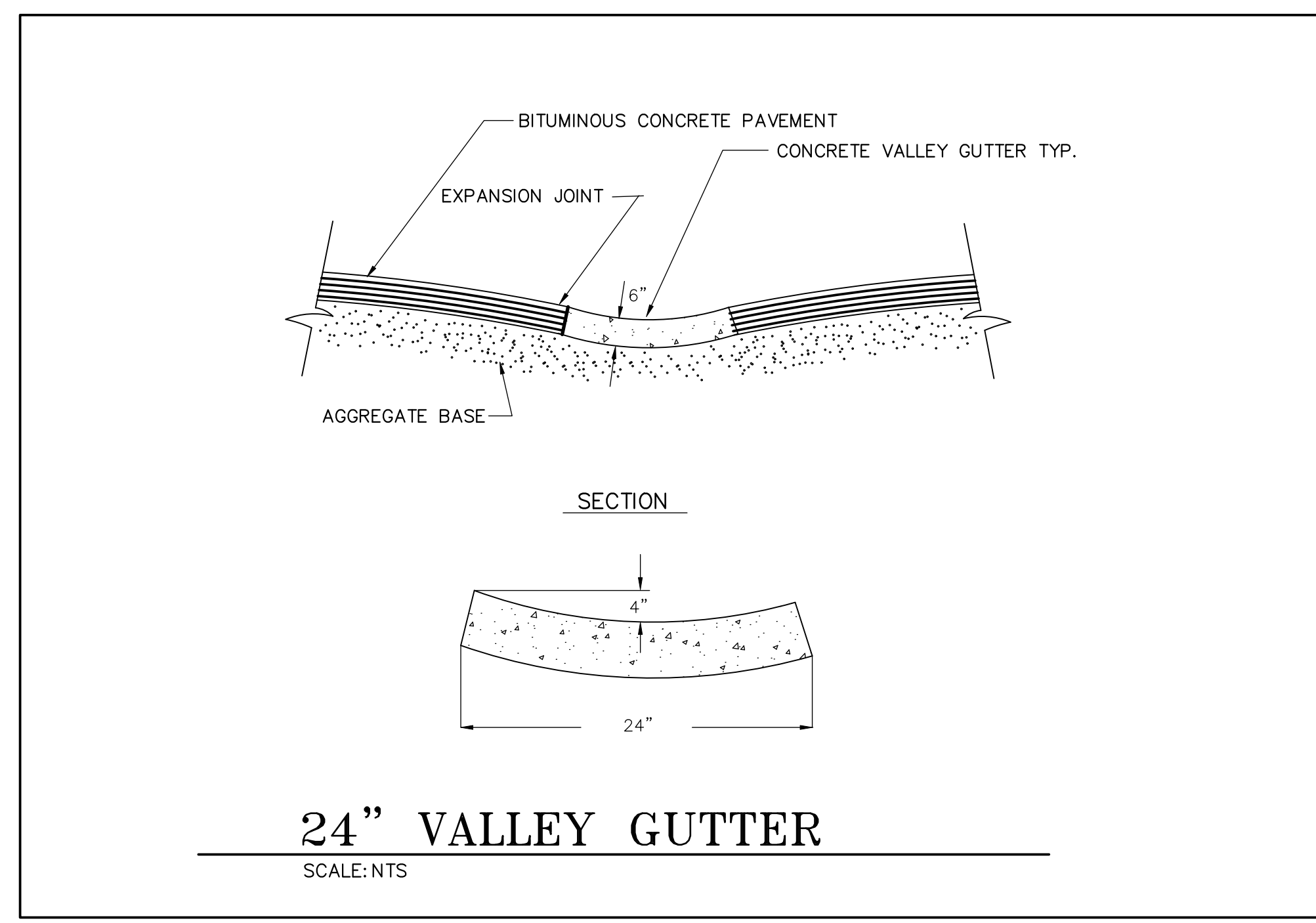

RAE
RICHARDS & ASSOCIATES ENGINEERING, INC.
CIVIL ENGINEERING + LAND PLANNING
P.O. BOX 220, CHATSWORTH, GA 30705
(706) 616-5906

PHASE #3
DALTON WHITFIELD COUNTY PUBLIC LIBRARY
READING PAVILION
310 CAPPES STREET. DALTON, GA

JOB NO: RAE 24-018
DATE: 10/20/25
DRAWN BY: SRR
REVISIONS:

DRAWING TITLE

SITE PLAN

SHEET NO.

C9

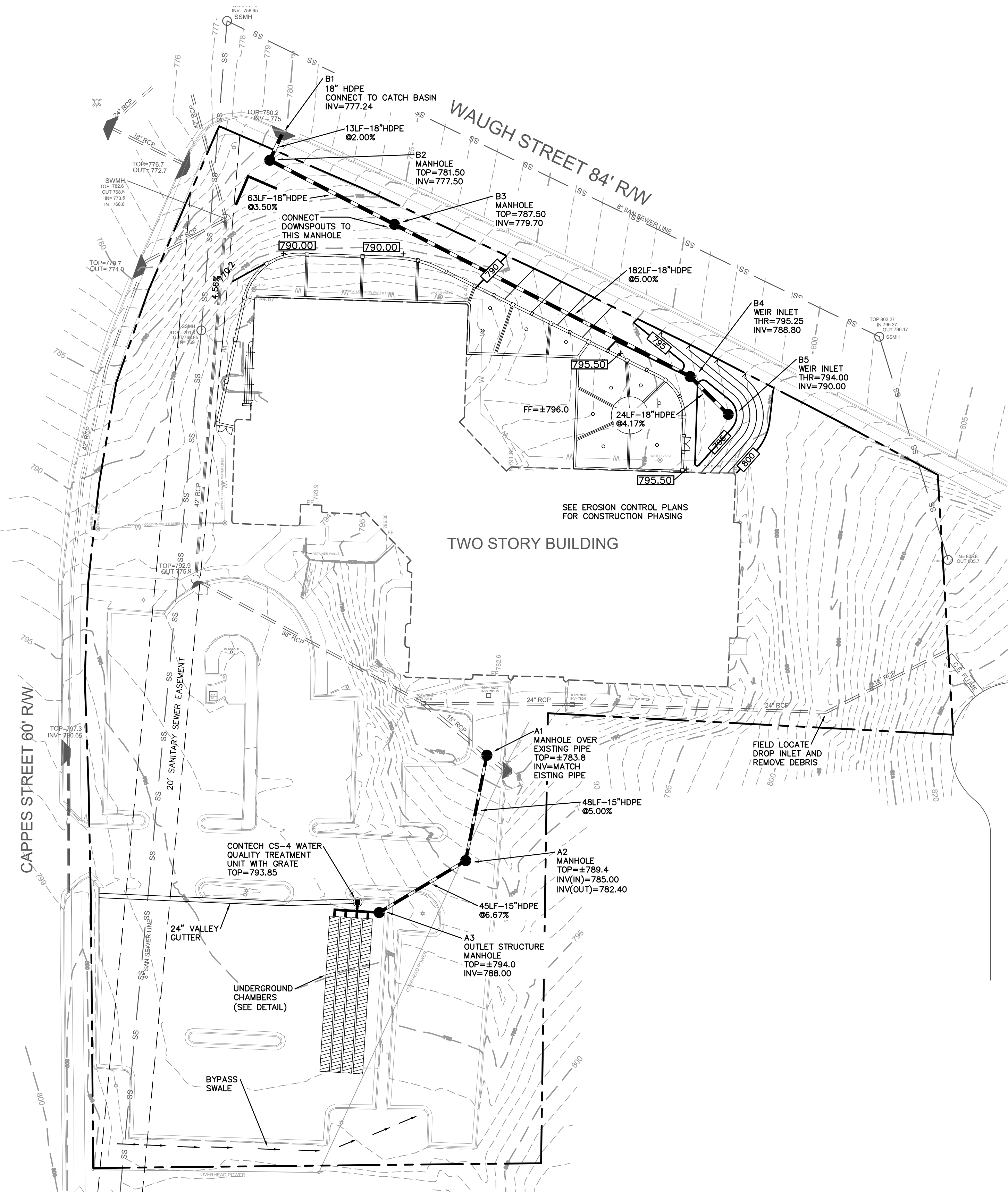
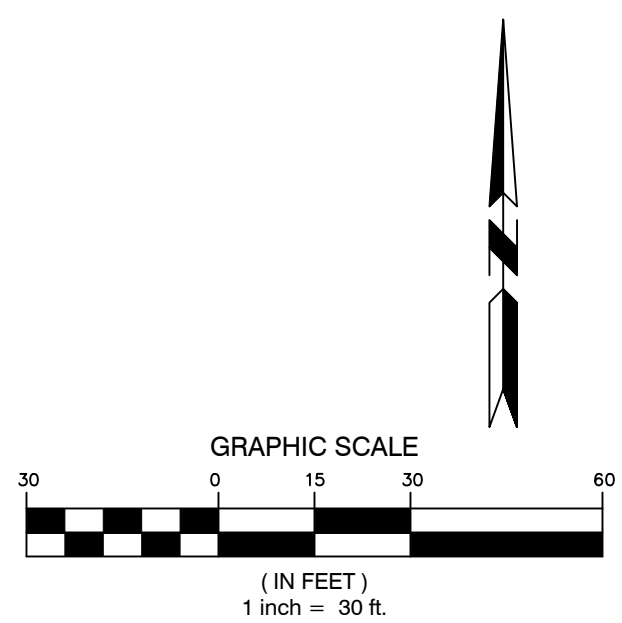

POND OPERATIONS & MAINTENANCE

1. AT THE COMPLETION OF CONSTRUCTION, ALL SEDIMENT AND DEBRIS SHOULD BE REMOVED FROM THE POND & STRUCTURES AND ALL TEMPORARY STRUCTURES REMOVED. THE UNDERCUT AREA SHOULD BE BACKFILLED WITH ACCEPTABLE MATERIAL AND A LAYER OF TOP SOIL, AND GRASSED WITH PERMANENT VEGETATION.
2. A VISUAL INSPECTION SHOULD BE PERFORMED AFTER THE FIRST QUALIFYING RAINFALL EVENT TO ENSURE THAT THE ACCUMULATED WATER IN THE POND HAS DRAWN DOWN OVER A 24-48 HOUR PERIOD. THE POND SHOULD BE MONITORED REGULARLY TO ENSURE THAT THE POND AND STRUCTURES CONTINUE TO OPERATE PROPERLY.
3. THE SIDES AND BOTTOM OF THE POND SHOULD BE MOWED MONTHLY TO LIMIT UNWANTED VEGETATION AND IMPROVE AESTHETICS.
4. THE DEVELOPER ASSUMES ALL RESPONSIBILITY FOR OPERATIONS AND MAINTENANCE OF THE POND AND ASSOCIATED STRUCTURES.
5. SEE DETAIL ON SHEET C3 FOR MICROPOOL. REMOVE SEDIMENT FROM MICROPOOL AND FOREBAY WHEN IT REACHES 4 INCHES DEEP.
6. A MAINTENANCE AGREEMENT IS REQUIRED BETWEEN LOCAL COUNTY JURISDICTION AND THE OWNER.

GRADING & DRAINAGE LEGEND

PROPOSED CURB	
PROPERTY LINE	
PROPOSED STORM SEWER	
PROPOSED STORM INLET	
EXISTING STORM SEWER	
EXISTING CONTOUR	
PROPOSED CONTOUR	
SOIL BOUNDARY	
PROPOSED SPOT ELEVATION	
EXISTING SPOT ELEVATION	
DROP INLET	
SAFETY END SECTION	
HEADWALL	
JUNCTION BOX	
REINFORCED CONCRETE PIPE	
CORRUGATED METAL PIPE	
RIP-RAP	
EXISTING FEATURES ARE SCREENED	

UG STORAGE:
100YR WATER EL=791.96
100YR WATER STORAGE VOL=3,707c³



Northwest Georgia Regional Library System
Dalton-Whitfield • Calhoun-Gordon • Chatsworth-Murray

GRADING AND DRAINAGE NOTES

1. CONTRACTOR SHALL VERIFY EXISTING TOPOGRAPHIC DATA, LOCATIONS OF EXISTING UTILITIES, AND ALL OTHER SITE CONDITIONS PRIOR TO BEGINNING CONSTRUCTION.
2. ALL CUT AND FILL SLOPES SHALL BE 4:1 OR FLATTER (SEE PLANS).
3. THE MICROPOOL AND ALL POND SLOPES SHALL BE STABILIZED WITH CONTECH TRM C-45 TURF REINFORCEMENT MATTING OR APPROVED EQUAL. ALL OTHER CUT AND FILL SLOPES STEEPER THAN 3:1 AND GREATER THAN 10 FEET IN HEIGHT, AND ALL DRAINAGE CHANNELS SHALL BE STABILIZED WITH THE SAME.
4. PLACE 4" OF TOPSOIL OVER THE ENTIRE POND AREA TO SUPPORT VEGETATION.
5. ALL CONSTRUCTION WITHIN STREET RIGHT-OF-WAY SHALL CONFORM TO WHITFIELD COUNTY REQUIREMENTS.
6. ALL FINISHED GRADES SHOWN ARE TO THE TOP OF THE PAVEMENT SECTION OR BOTTOM OF CURB UNLESS OTHERWISE NOTED.
7. CONTRACTOR SHALL CONFINE HIS OFF-SITE ACTIVITIES TO EXISTING RIGHTS OF WAY AND EASEMENTS.
8. ALL HIGH DENSITY POLYETHYLENE (HDPE) PIPE SHALL BE SMOOTH-LINED AND MANUFACTURED IN ACCORDANCE WITH AASHTO M-294, TYPE S. ALL JOINTS SHALL BE WATERTIGHT PER ASTM-D3212. JOINT GASKETS SHALL MEET THE REQUIREMENTS OF ASTM-F477. INSTALLATION SHALL BE IN ACCORDANCE WITH SECTION 550 OF THE GEORGIA DOT STANDARD SPECIFICATIONS, CONSTRUCTION OF ROADS AND BRIDGES.
9. ALL RCP PIPE JOINTS SHALL BE BELL & SPIGOT TYPES WITH A RUBBER GASKET CONFORMING TO ASTM C-443. THE PIPE SHALL BE MANUFACTURED IN ACCORDANCE WITH AASHTO M-170 AND/OR ASTM C-76. CLASS OF PIPE AN WALL THICKNESS SHALL BE IN ACCORDANCE WITH 1030-D, GEORGIA DOT SPECIFICATION, TABLE NO. 1. INSTALLATION SHALL BE IN ACCORDANCE WITH SECTION 550 OF THE GEORGIA DOT STANDARD SPECIFICATIONS, CONSTRUCTION OF ROADS AND BRIDGES.
10. PER LOCAL JURISDICTION DESIGN MANUAL, MINIMUM BEDDING STANDARDS FOR HDPE AND CMP; STONE BEDDING SHALL BE PLACED TO HALF OF THE PIPE DIAMETER FOR ALL DEPTHS GREATER THAN 4 FEET, OR IN ACCORDANCE WITH THE MANUFACTURER'S SPECIFICATIONS, WHICHEVER IS GREATER.
11. FOR THE DOWNSPOUT COLLECTION PIPING, HDPE FITTINGS MAY BE USED IN PLACE OF MANHOLES IF A METHOD OF CLEANOUT IS PROVIDED AT EACH BEND. PROVIDE A METHOD OF CLEANOUT AT EACH DOWNSPOUT CONNECTION.
12. THE CONTRACTOR IS RESPONSIBLE FOR INSTALLING ALL IMPROVEMENTS PER LOCAL COUNTY JURISDICTION SPECIFICATIONS AND REQUIREMENTS. THE CONTRACTOR MUST OBTAIN A COPY OF THE LOCAL STANDARDS PRIOR TO BIDDING THIS PROJECT. IF THESE PLANS ARE FOUND TO BE OUT OF SPEC, THE CONTRACTOR SHALL CEASE WORK IMMEDIATELY AND SHALL NOTIFY THE OWNER WITHIN 24 HOURS.
13. ALL PIPE LENGTHS AND SLOPES ARE SHOWN TO THE CENTER OF THE STORM STRUCTURE AND ARE APPROXIMATE. THE CONTRACTOR IS RESPONSIBLE FOR DETERMINING THE EXACT PIPE LENGTHS BASED ON THE TYPE AND SIZE OF STRUCTURE USED AND THE INLET TOP REQUIRED. THE CONTRACTOR IS RESPONSIBLE FOR DETERMINING THE EXACT LOCATION OF THE STORM STRUCTURE BASED ON THE INLET TOP REQUIRED.
14. CONTRACTOR MUST ENSURE THAT ALL DOWNSTREAM DRAINAGE WAYS ARE CLEAR OF DEBRIS PRIOR TO FINAL INSPECTION BY THE ENGINEER. COORDINATE WITH NEIGHBORS OR APPROPRIATE RIGHT-OF-WAY AUTHORITY PRIOR TO BEGINNING WORK OUTSIDE THE BOUNDARY OF THIS SITE. CONTRACTOR IS RESPONSIBLE FOR ANY DAMAGE TO OFF-SITE PROPERTIES.
15. AN AS-BUILT SURVEY MUST BE PREPARED AND CERTIFIED BY RICHARDS & ASSOCIATES AND LOCAL COUNTY JURISDICTION APPROVAL WILL BE REQUIRED AFTER COMPLETION OF THE DETENTION POND. THE POND MUST BE BUILT AS DESIGNED. ANY DEVIATION FROM THE DESIGN MUST HAVE PRIOR APPROVAL FROM RICHARDS & ASSOCIATES AND MAY REQUIRE APPROVAL BY LOCAL COUNTY JURISDICTION.

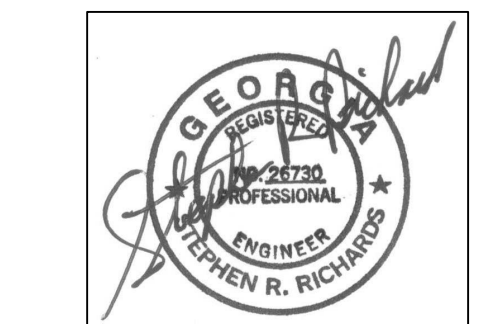
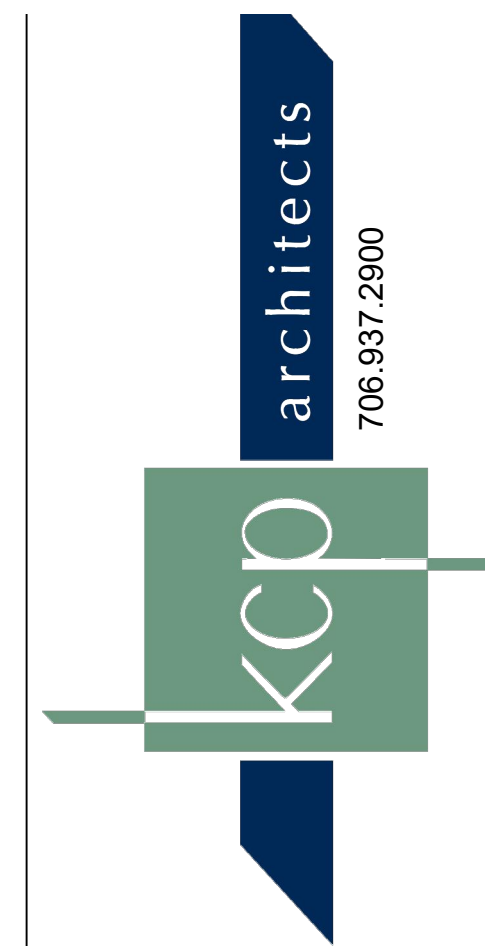

GA PROFESSIONAL ENGINEER NO. 26730
LEVEL II CERTIFIED DESIGN
PROFESSIONAL NO. 8688

PHASE #3
DALTON WHITFIELD COUNTY PUBLIC LIBRARY
READING PAVILION
310 CAPPES STREET. DALTON, GA

JOB NO.	RAE 24-018
DATE	10/20/25
DRAWN BY	SRR
REVISIONS	

DRAWING TITLE
GRADING AND DRAINAGE PLAN

SHEET NO.
C10



RICHARDS & ASSOCIATES ENGINEERING, INC.
CIVIL ENGINEERING + LAND PLANNING
P.O. BOX 220, CHATSWORTH, GA 30705
(706) 616-5906

© RICHARDS & ASSOC. ENGINEERING, INC.

PROJECT SUMMARY

- DESIGN PARAMETERS**
- PRE-TREATMENT METHOD = Hydrodynamic Separator
 - STORAGE VOLUME REQUIRED = 28259^{ft}
 - INVERT DEPTH = 6^{ft}
 - MANHOLE DIAMETER = 12ⁱⁿ
 - SPACING BETWEEN CHAMBERS = 5.6^{ft}
 - SIDE PERIMETER STONE WIDTH = 12ⁱⁿ
 - END PERIMETER STONE WIDTH = 12ⁱⁿ
 - TOP PERIMETER STONE WIDTH = 6ⁱⁿ
 - BOTTOM PERIMETER STONE WIDTH = 6ⁱⁿ
 - STONE POROSITY = 40%
- SYSTEM DETAILS**
- TOTAL ELBOW MANIFOLDS = 1
 - TOTAL TEE MANIFOLDS = 3
 - TOTAL START CHAMBERS = 4
 - TOTAL MID CHAMBERS = 28
 - TOTAL END CHAMBERS = 4
 - TOTAL NUMBER OF CHAMBERS = 36
 - NUMBER OF ROWS = 4
 - CHAMBERS PER ROW = 9
 - CHAMBER STORAGE VOLUME = 1707.29^{ft}
 - MANHOLE STORAGE VOLUME = 22.599^{ft}
 - BACKFILL STORAGE VOLUME = 1068.458^{ft}
 - TOTAL STORAGE PROVIDED = 2825.999^{ft}
- SYSTEM DIMENSIONS AND OTHER MATERIALS**
- RECTANGULAR FOOTPRINT = 70.4x20.53^{ft}
 - TOTAL EXCAVATION = 348.7^{ft}
 - STONE BACKFILL = 125.05^{ft}
 - REMAINING BACKFILL TO PAVEMENT = 159.8^{ft}
 - REMAINING BACKFILL TO VORTSSENTRY HS = 159.8^{ft}
 - WOVEN GEOTEXTILE QTY = 5^{ft}
 - NON-WOVEN GEOTEXTILE QTY = 160.84^{ft}
 - SCOUR PROTECTION FITTING = 20.53x7.5^{ft}
 - APPROXIMATE TRUCKLOADS = 1

GENERAL NOTES

- ALL ELEVATIONS, DIMENSIONS AND LOCATIONS OF RISERS AND INLETS SHALL BE VERIFIED BY THE ENGINEER OF RECORD.
- PRIOR TO INSTALLATION OF THE CHAMBERMAXX SYSTEM A PRE-CONSTRUCTION MEETING SHALL BE CONDUCTED. THOSE REQUIRED TO ATTEND ARE THE SUPPLIER OF THE SYSTEM, THE GENERAL CONTRACTOR, SUB-CONTRACTORS AND THE ENGINEER.
- CHAMBERMAXX CHAMBERS ARE MANUFACTURED FROM POLYPROPYLENE PLASTIC.
- CHAMBERMAXX SYSTEM TO MEET AASHTO HS20HS25 LIVE LOADING, PER AASHTO LRFD SECTION 12.
- ACCESS COVERS TO MEET AASHTO HS20HS25 LIVE LOADING.
- MINIMUM COVER IS 18-INCHES TO BOTTOM OF FLEXIBLE PAVEMENT OR TO TOP OF RIGID PAVEMENT. FOR COVER HEIGHTS GREATER THAN 96-INCHES CONTACT YOUR LOCAL REPRESENTATIVE.
- ALL PARTS PROVIDED BY CONTECH UNLESS OTHERWISE NOTED.
- FOR INFORMATION ON PRE-TREATMENT SYSTEMS, REFERENCE CONTECH PRE-TREATMENT SYSTEM STANDARD DETAILS OR CONTACT YOUR LOCAL REPRESENTATIVE.
- CHAMBERMAXX BY CONTECH ENGINEERED SOLUTIONS (800) 925-5242

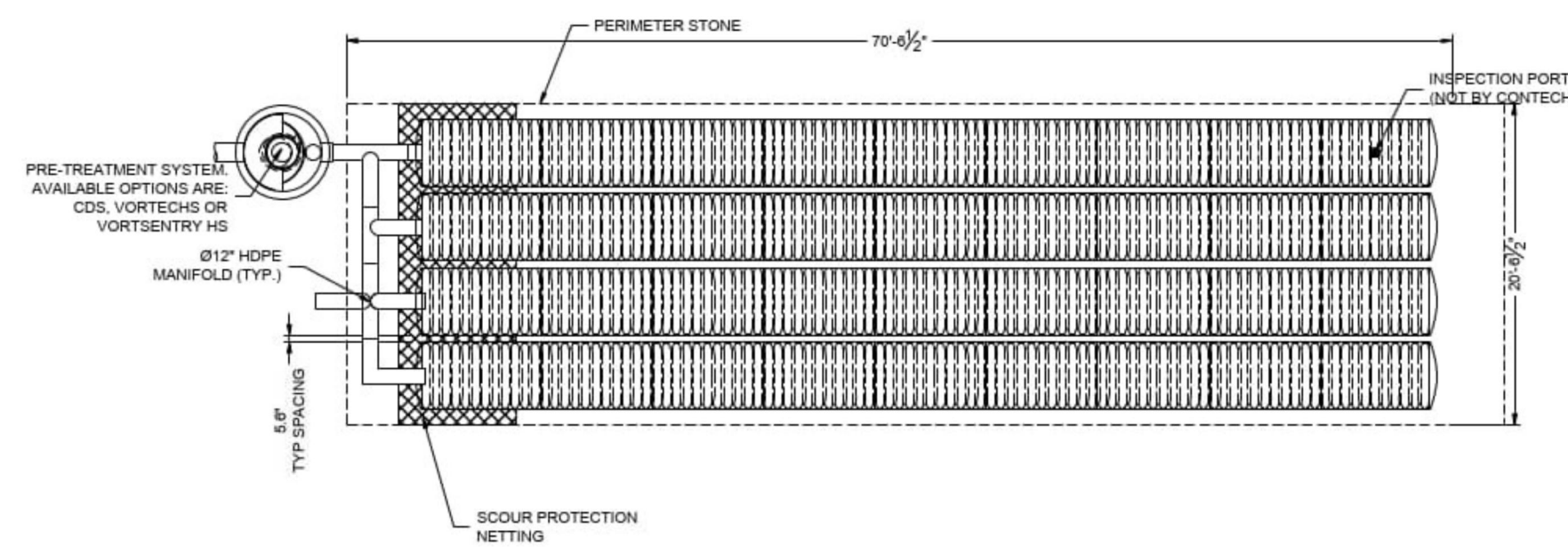

NO.	DATE	REVISION DESCRIPTION	BY

PROJECT NO.	8816	REV. NO.	0607/2024
DRAWN BY	DYO	CHECKED BY	DYO
DATE	07/20/24	SCALE	D1 OF D4

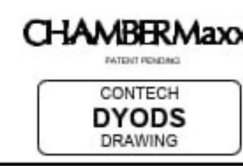

DYO56941 Dalton Library
Dalton, GA
CHAMBERMAXX

INSTALLATION NOTES

- CHAMBERMAXX INSTALLATION GUIDE TO BE REVIEWED BY CONTRACTOR PRIOR TO INSTALLATION.
- PRIOR TO PLACING BEDDING, THE FOUNDATION MUST BE CONSTRUCTED TO A UNIFORM AND STABLE GRADE. IN THE EVENT THAT UNSUITABLE FOUNDATION MATERIALS ARE ENCOUNTERED DURING EXCAVATION, UNSUITABLE MATERIAL SHALL BE REMOVED AND BROUGHT BACK TO GRADE WITH FILL MATERIALS APPROVED BY THE ENGINEER OF RECORD. ONCE THE FOUNDATION PREPARATION IS COMPLETE, THE BEDDING MATERIAL CAN BE PLACED.
- THE SCOUR PROTECTION NETTING TO BE EXTENDED 1' BEYOND OUTSIDE EDGE OF INLET CHAMBERS.
- COVER ANY OPEN VOID SPACES GREATER THAN 3/4" ON CHAMBERS WITH A NON-WOVEN GEOTEXTILE TO PREVENT INFILTRATION OF BACKFILL MATERIAL.
- STONE EMBLEMMENT MATERIAL SHALL BE INSTALLED TO 95% STANDARD PROCTOR DENSITY AND PLACED IN 6-INCH TO 8-INCH LIFTS SUCH THAT THERE IS NO MORE THAN A TWO LIFT DIFFERENTIAL BETWEEN ANY OF THE CHAMBERS AT ANY TIME. GRANULAR BACKFILL MATERIAL SHALL BE COMPACTED TO 95% SPD. BACKFILLING SHALL BE ADVANCED ALONG THE LENGTH OF THE CHAMBER ROWS AT THE SAME RATE TO AVOID DIFFERENTIAL LOADING AND DISPLACEMENT OF THE CHAMBERS. THE MINIMUM CHAMBER SPACING MUST BE MAINTAINED.
- REFER TO CHAMBERMAXX INSTALLATION GUIDE FOR TEMPORARY CONSTRUCTION LOADING GUIDELINES.
- IT IS ALWAYS THE CONTRACTOR'S RESPONSIBILITY TO FOLLOW OSHA GUIDELINES FOR SAFE PRACTICES.
- GENERAL INSTALLATION METHODS AND MATERIALS TO BE IN ACCORDANCE WITH ASTM D2021.

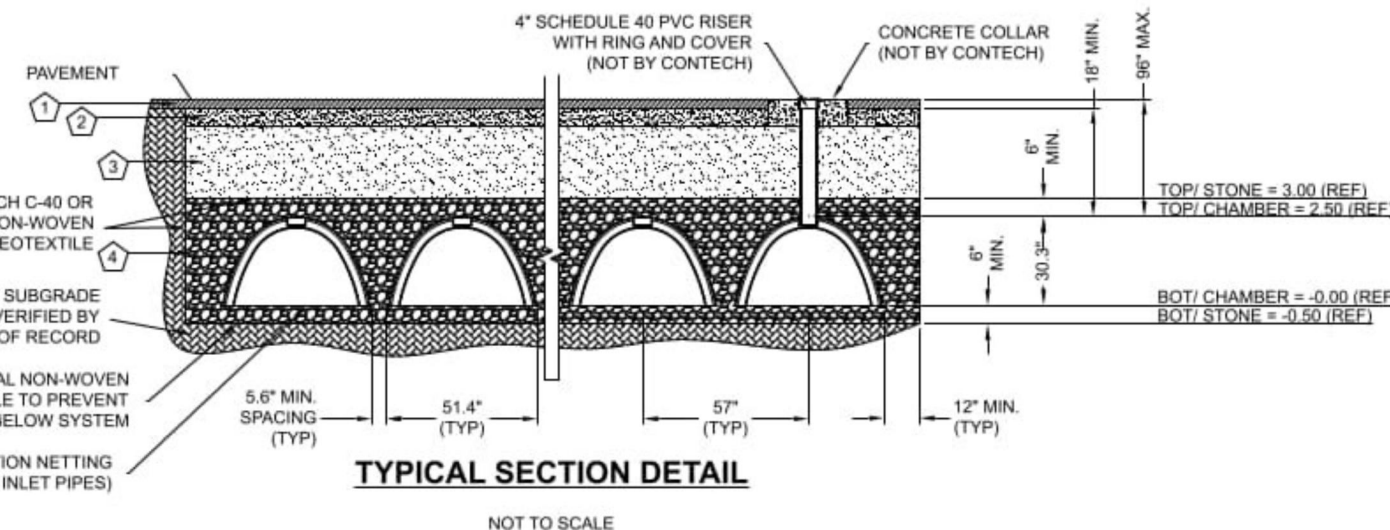

TYPICAL SECTION DETAIL

- KEY:
- FLEXIBLE PAVEMENT
 - GRANULAR ROAD BASE
 - ANY SUITABLE NATIVE OR GENERAL BACKFILL, SEE ENGINEER PLANS.
 - THE BACKFILL MATERIAL SHALL BE FREE-DRAINING ANGULAR WASHED STONE 3/4" - 2" PARTICLE SIZE. MATERIAL SHALL BE PLACED IN 6"-10" MAXIMUM LIFTS. MATERIAL SHALL BE WORKED INTO THE CHAMBER SPACING BY MEANS OF SHOVEL, SLICING, ROOFCING, AIR TRAMP, VIBRATORY ROD, OR OTHER EFFECTIVE METHODS. COMPACTION IS CONSIDERED ADEQUATE WHEN NO FURTHER YIELDING OF THE MATERIAL IS OBSERVED UNDER THE COMPACTOR, OR UNDER FOOT AND THE PROJECT ENGINEER OR THEIR REPRESENTATIVE IS SATISFIED WITH THE LEVEL OF COMPACTION. INADEQUATE COMPACTION CAN LEAD TO EXCESSIVE DEFLECTIONS WITHIN THE SYSTEM AND SETTLEMENT OF THE SOILS OVER THE SYSTEM. BACKFILL SHALL BE PLACED SUCH THAT THERE IS NO MORE THAN A TWO-LIFT DIFFERENTIAL BETWEEN THE SIDES OF ANY CHAMBER IN THE SYSTEM AT ALL TIMES DURING THE BACKFILL PROCESS. BACKFILL SHALL BE ADVANCED ALONG THE LENGTH OF THE SYSTEM AT THE SAME RATE TO AVOID DIFFERENTIAL LOADING ON ANY PIPES IN THE SYSTEM.

EQUIPMENT USED TO PLACE AND COMPACT THE BACKFILL SHALL BE OF A SIZE AND TYPE SO AS NOT TO DISTORT, DAMAGE, OR DISPLACE THE CHAMBERS. ATTENTION MUST BE GIVEN TO PROVIDING ADEQUATE MINIMUM COVER FOR SUCH EQUIPMENT, AND MAINTAIN BALANCED LOADING ON ALL CHAMBERS IN THE SYSTEM DURING ALL SUCH OPERATIONS. OTHER ALTERNATE BACKFILL MATERIAL MAY BE ALLOWED DEPENDING ON SITE SPECIFIC CONDITIONS. CONTACT YOUR LOCAL CONTECH REPRESENTATIVE FOR DETAILS.

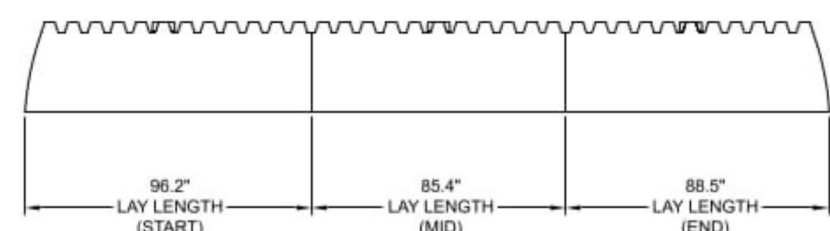

TYPICAL ELEVATION VIEW

NOT TO SCALE

FEATURE	START CHAMBER	MIDDLE CHAMBER	END CHAMBER
OVERALL CHAMBER HEIGHT - IN	30.3	30.3	30.3
OVERALL CHAMBER WIDTH - IN	51.4	51.4	51.4
ACTUAL LENGTH - IN	98.4	91.0	92.0
INSTALLED LAY LENGTHS - IN	96.2	85.4	88.5
CHAMBER STORAGE VOLUME - CF	50.2	47.2	46.2
CHAMBER STORAGE PER LINEAR FOOT - CF/LF	6.3	6.6	6.3
MIN. INSTALLED CHAMBER VOLUME - CF	78.1	75.1	74.1
MIN. INSTALLED CHAMBER VOLUME PER LINEAR FOOT - CF/LF	9.7	10.6	10.0
CHAMBER WEIGHT - LB	83	73	76

NO.	DATE	REVISION DESCRIPTION	BY

PROJECT NO.	8816	REV. NO.	0607/2024
DRAWN BY	DYO	CHECKED BY	DYO
DATE	07/20/24	SCALE	D2 OF D4

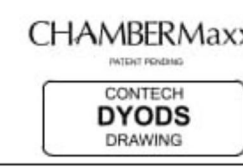

DYO56941 Dalton Library
Dalton, GA
CHAMBERMAXX

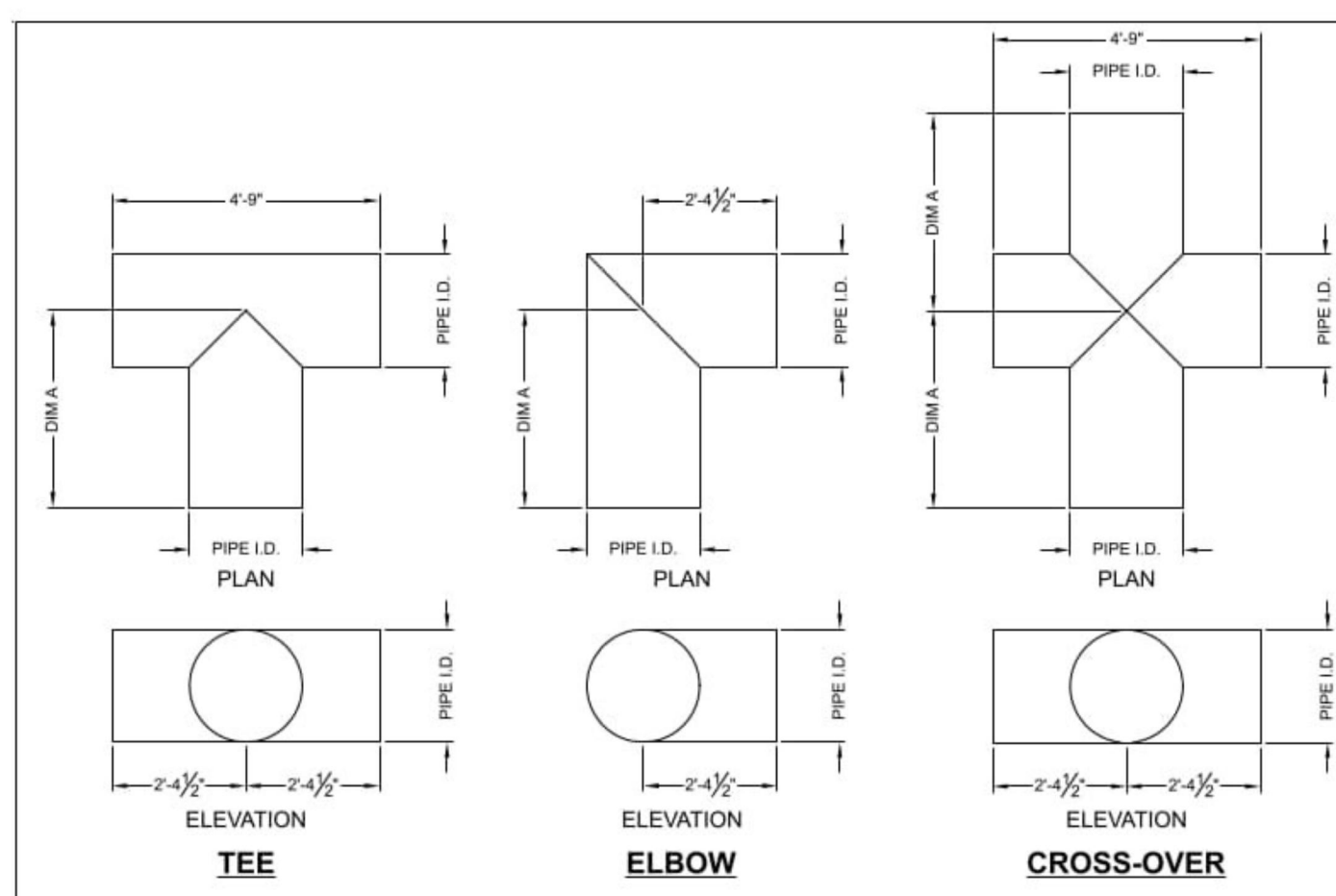

STANDARD MANIFOLD COMPONENTS - NOT TO SCALE

	AVAILABLE DIAMETERS - INCHES			
TEE	12	15	18	24
ELBOW	12	15	18	24
DIM A	42	42	48	48

- GENERAL NOTES:**
- FITTING MATERIAL TO BE MANUFACTURED FROM CORRUGATED HIGH DENSITY POLYETHYLENE, AASHTO M284 PIPE.
 - FITTINGS TO BE FABRICATED IN ACCORDANCE WITH THE REQUIREMENT OF AASHTO M284.
 - FITTINGS DESIGNED TO PROTRUDE 6" INTO THE END OF THE INLET CHAMBERS.
 - MANIFOLD TEE AND ELBOW JOINT TO BE CONNECTED UTILIZING HDPE SPLIT COUPLERS.

TYPICAL MANIFOLD DETAILS

NO.	DATE	REVISION DESCRIPTION	BY

PROJECT NO.	8816	REV. NO.	0607/2024
DRAWN BY	DYO	CHECKED BY	DYO
DATE	07/20/24	SCALE	D3 OF D4

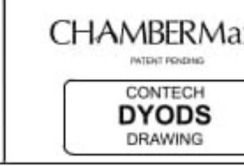

DYO56941 Dalton Library
Dalton, GA
CHAMBERMAXX

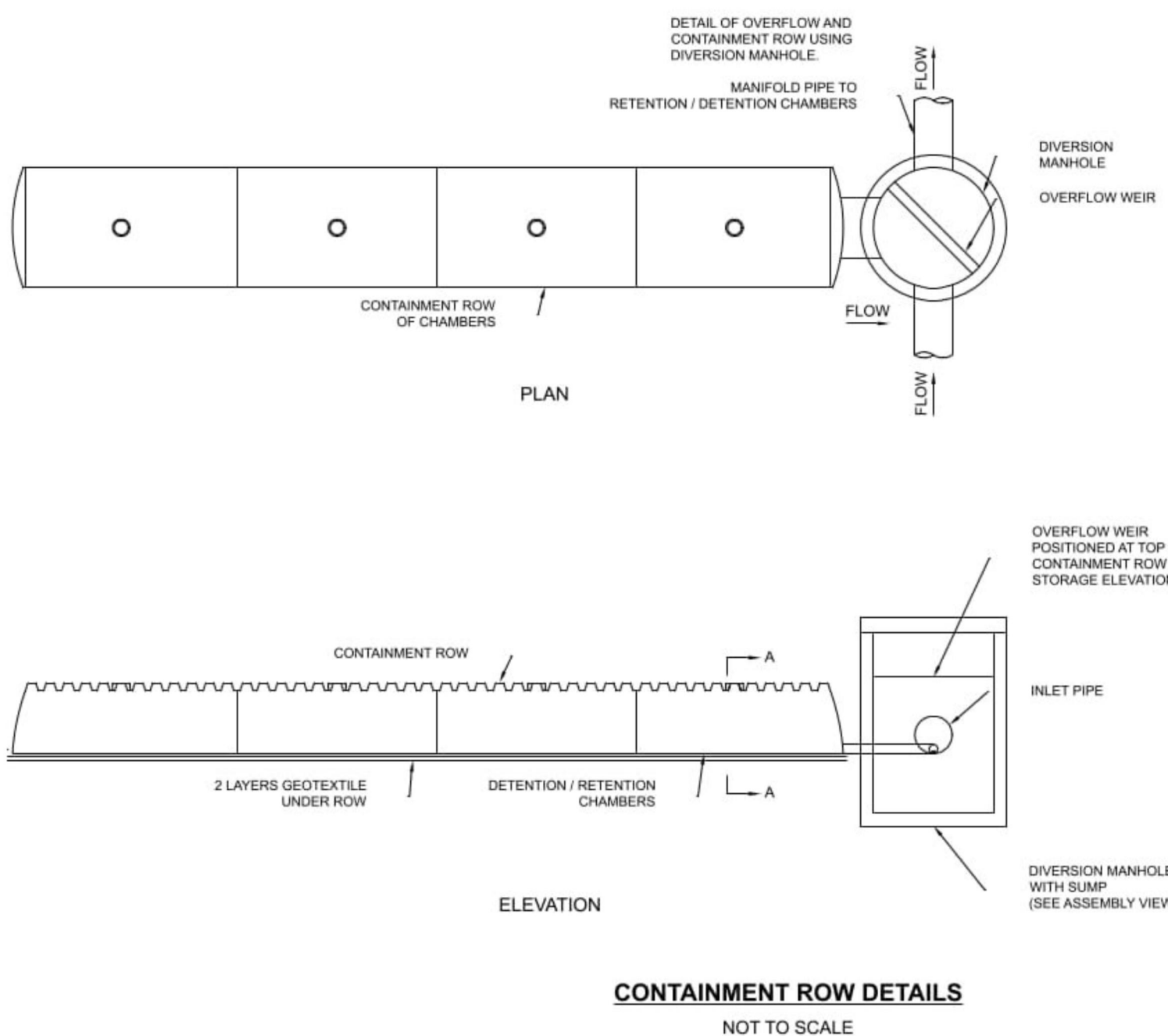

CONTAINMENT ROW DETAILS

NOT TO SCALE

NO.	DATE	REVISION DESCRIPTION	BY

PROJECT NO.	8816	REV. NO.	0607/2024
DRAWN BY	DYO	CHECKED BY	DYO
DATE	07/20/24	SCALE	D4 OF D4

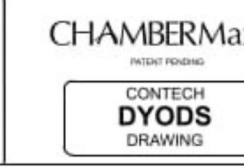

DYO56941 Dalton Library
Dalton, GA
CHAMBERMAXX



Northwest Georgia Regional Library System
Dalton-Whitfield • Calhoun-Gordon • Chatsworth-Murray

RING AND COVER DETAIL

NOT TO SCALE

INSPECTION PORT DETAIL

NOT TO SCALE

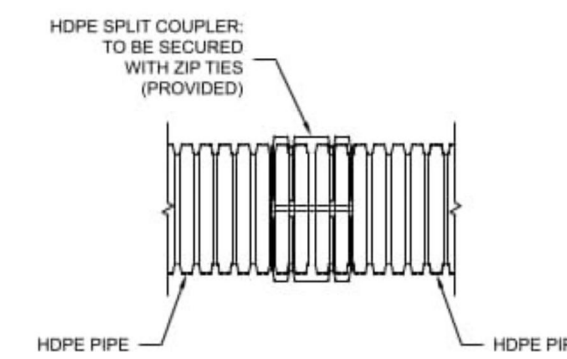

HDPE SPLIT COUPLER DETAIL

HDPE SPLIT COUPLERS

COUPLER SIZE	PART NUMBER
12" SPLIT COUPLER	PEF12SPCP
15" SPLIT COUPLER	PEF15SPCP
18" SPLIT COUPLER	PEF18SPCP
24" SPLIT COUPLER	PEF24SPCP

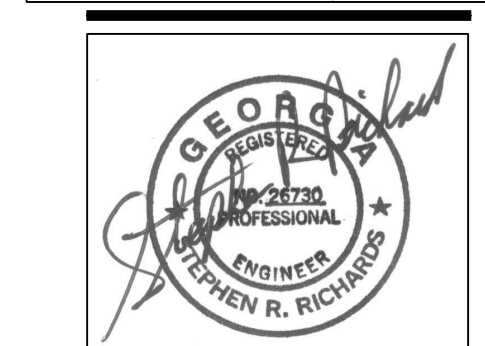
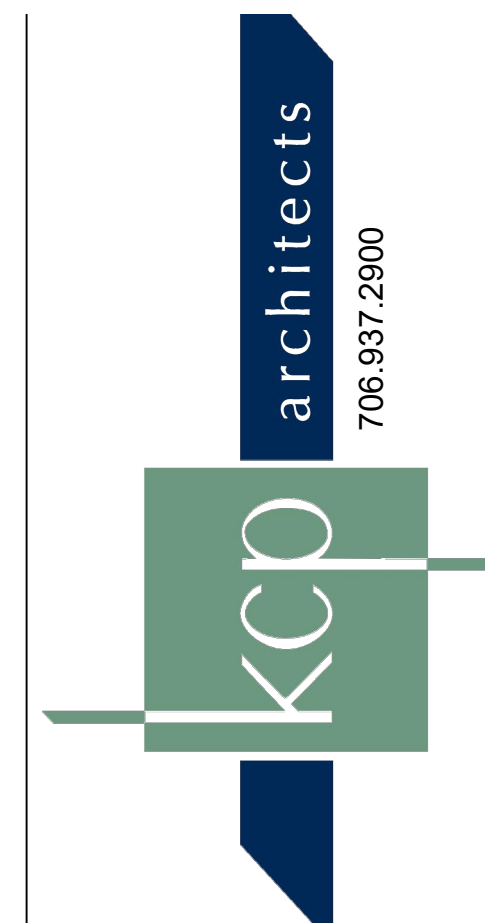

GA PROFESSIONAL ENGINEER NO. 26730
LEVEL II CERTIFIED DESIGN PROFESSIONAL NO. 8688

PHASE #3
DALTON WHITFIELD COUNTY PUBLIC LIBRARY
READING PAVILION
310 CAPPES STREET.
DALTON, GA

JOB NO.	RAE 24-018
DATE	10/20/25
DRAWN BY	SRR
REVISIONS	

CONSTRUCTION DETAILS

SHEET NO. C11



© RICHARDS & ASSOC. ENGINEERING, INC.

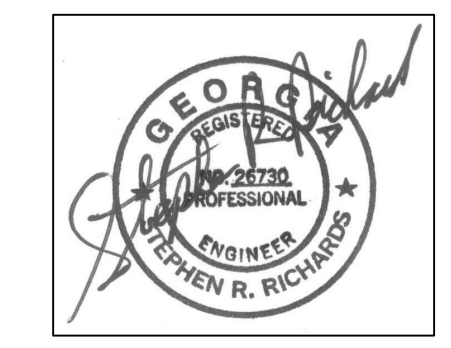
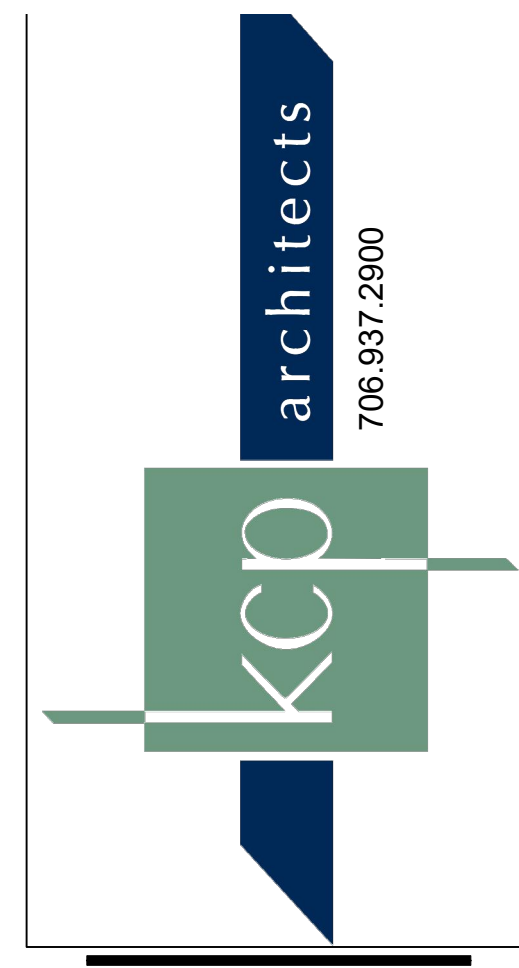
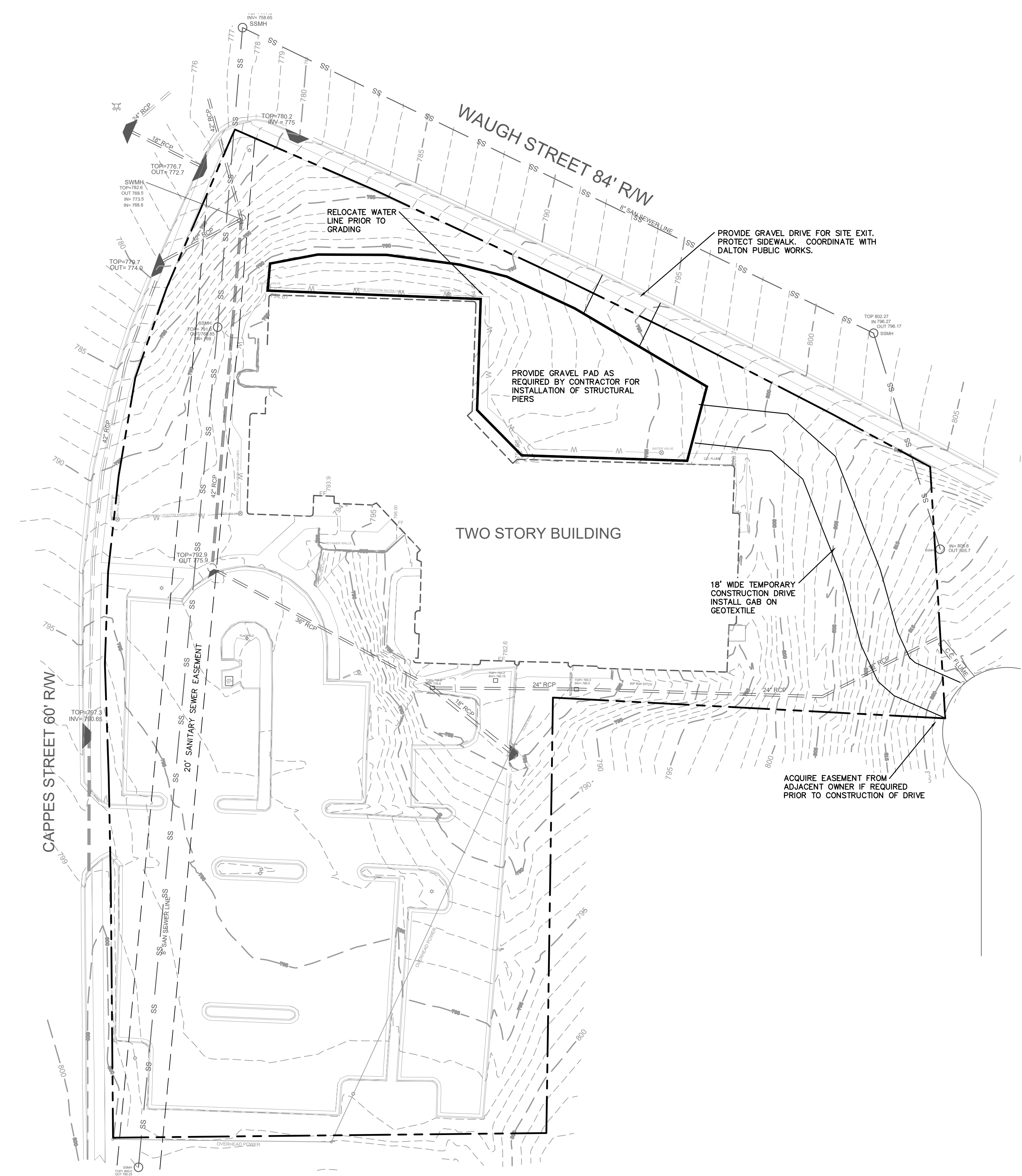
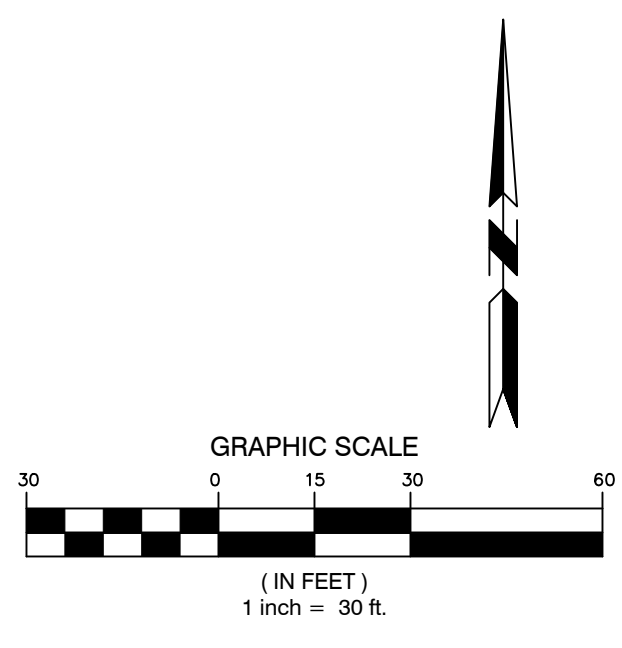

GA PROFESSIONAL ENGINEER NO. 26730
 LEVEL II CERTIFIED DESIGN
 PROFESSIONAL NO. 8688

PHASE #3
 DALTON WHITFIELD COUNTY PUBLIC LIBRARY
READING PAVILION
 310 CAPPES STREET. DALTON, GA

JOB NO.	RAE 24-018
DATE	10/20/25
DRAWN BY	SRR
REVISIONS	

DRAWING TITLE	
---------------	--

PHASE 1
 CONSTRUCTION
 PLAN

SHEET NO.
C12



© RICHARDS & ASSOC. ENGINEERING, INC.